

GEOMETRIZED VACUUM PHYSICS. PART IV: DYNAMICS OF VACUUM LAYERS

Mikhail Batanov-Gaukhman¹

(1) Moscow Aviation Institute (National Research University),
Institute No. 2 “Aircraft and rocket engines and power plants”,
st. Volokolamsk highway, 4, Moscow – Russia, 125993
(e-mail: alsignat@yandex.ru)

ABSTRACT

This article is the fourth part of a scientific project under the general title “Geometrized vacuum physics based on the Algebra of Signatures”. In the first three articles [1,2,3], the foundations of the Algebra of Signatures were laid and the main aspects of the kinematics of vacuum layers were considered. This article continues the development of the mathematical apparatus of the proposed project, in particular, the dynamics of vacuum layers is developed based on the Algebra of Signatures. The development of this direction of research (with simplifications related to Riemann's differential geometry) led to the possibility of a geometrized representation of the electric field strength and magnetic field induction. This geometrized mathematical apparatus allows one to interpret the electromagnetic field as an interweaving of accelerated and rotational flows of the adjacent layers of vacuum. The proposed dynamic models of accelerated movements and rotations of vacuum layers can provide a theoretical basis for the development of “zero” (i.e. vacuum) technologies.

RESUMEN

Este artículo es la cuarta parte de un proyecto científico bajo el título general “Física del vacío geometrizada basada en el Álgebra de Signatures”. En los primeros tres artículos [1,2,3] se sentaron las bases del Álgebra de Signatures y se consideraron los aspectos principales de la cinemática de las capas de vacío. Este artículo continúa el desarrollo del aparato matemático del proyecto propuesto, en particular, la dinámica de capas de vacío se desarrolla con base en el Álgebra de Signatures. El desarrollo de esta dirección de investigación (con simplificaciones relacionadas con la geometría diferencial de Riemann) condujo a la posibilidad de una representación geometrizada de la intensidad del campo eléctrico y la inducción del campo magnético. Este aparato matemático geometrizado permite interpretar el campo electromagnético como un entrelazamiento de flujos acelerados y rotacionales de las capas adyacentes de vacío. Los modelos dinámicos propuestos de movimientos acelerados y rotaciones de capas de vacío pueden proporcionar una base teórica para el desarrollo de tecnologías “cero” (es decir, de vacío).

Keywords: vacuum, geometrized vacuum physics, signature, algebra of signature, acceleration of the vacuum layer.

Palabras clave: vacío, física del vacío geometrizado, signatura, álgebra de signatura

BACKGROUND AND INTRODUCTION

This paper is the fourth in a series of articles under the general title “Geometrized vacuum physics”. In the previous three articles [1, 2, 3] the basics of the Algebra of Signatures and the kinematics of vacuum layers were outlined.

Let’s recall that the subject of study of Algebra of Signatures (abbreviated as Alsigna) is the volume of the “vacuum”, i.e. local 3-dimensional area of the void [1, 2, 3].

Within Alsigna, the “vacuum” is stratified into an infinite number of nested $\lambda_{m,n}$ -vacuums, which are illuminated from the void by probing it with monochromatic rays of light with wavelengths $\lambda_{m,n}$ from different ranges $\Delta\lambda = 10^m \div 10^n$ cm, where $n = m + 1$ (see §§1–2 in [1]). In this case, each $\lambda_{m,n}$ -vacuum is a $3D_{m,n}$ -landscape (or $3D_{m,n}$ -lattice), the geodesic lines of which are the corresponding rays of light (see Figure 1).

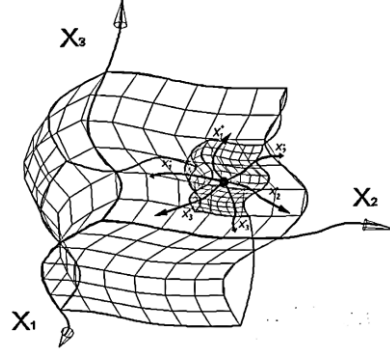

Fig. 1: $\lambda_{m,n}$ -vacuum is embedded in $\lambda_{f,d}$ -vacuum, where $\lambda_{f,d} > \lambda_{m,n}$ (repetition of Figure 3 in [3])

This article considers the geodesic lines of only one curved region of one of the $\lambda_{m,n}$ -vacuums. The geodesic lines of the remaining $\lambda_{m,n}$ -vacuum are studied similarly.

Let's recall that within the framework of the Algebra of Signature, the simplest level of research is a bilateral consideration of the uncurved local region of the 2^3 - $\lambda_{m,n}$ -vacuum (see §4 in [3] and Figure 2), which is specified by a set of pseudo-Euclidean metrics (83) in [3]

$$\begin{cases} ds_0^{(+)^2} = c^2 dt^2 - dx^2 - dy^2 - dz^2 = ds^{(+)' } ds^{(+)' ' } = c dt' c dt'' - dx' dx'' - dy' dy'' - dz' dz'', \\ ds_0^{(-)^2} = -c^2 dt^2 + dx^2 + dy^2 + dz^2 = ds^{(-)' } ds^{(-)' ' } = -c dt' c dt'' + dx' dx'' + dy' dy'' + dz' dz''. \end{cases} \quad (1)$$

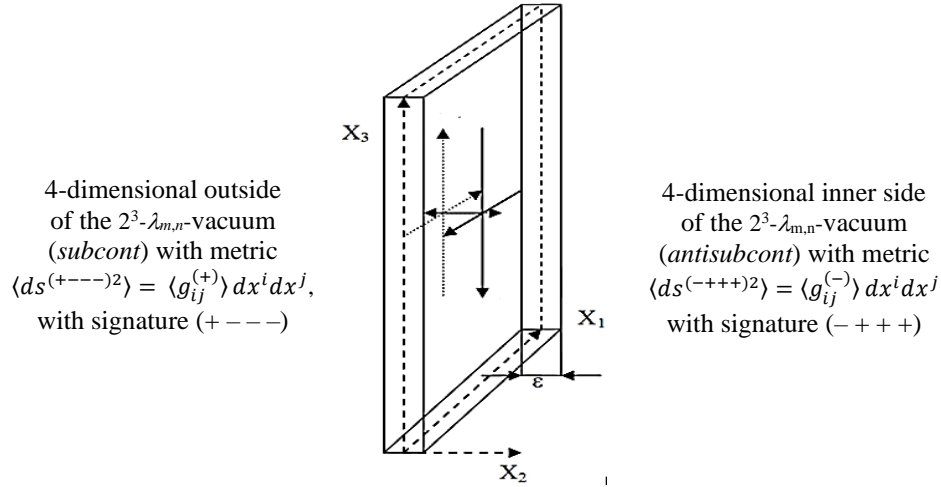

Fig. 1: Simplified illustration of a two-sided section of the 2^3 - $\lambda_{m,n}$ -vacuum, the outer side of which (*subcont*) is described by the averaged metric $\langle ds^{(+---)^2} \rangle$ with the signature $(+---)$, and its inner side (*antisubcont*) is described by the metric $\langle ds^{(-+++)^2} \rangle$ with the opposite signature $(-+++)$, as $\varepsilon \rightarrow 0$ (repetition of Figure 7 in [3])

The metric-dynamic state of the same, but curved section of the double-sided 2^3 - $\lambda_{m,n}$ -vacuum is described by the averaged metric (61) in [3]

$$ds^{(\pm)^2} = \frac{1}{2} (ds^{(+---)^2} + ds^{(-+++)^2}) = \frac{1}{2} (ds^{(+)^2} + ds^{(-)^2}) = \frac{1}{2} (g_{ij}^{(+)} + g_{ij}^{(-)}) dx^i dx^j, \quad (2)$$

where

$$ds^{(+---)2} = ds^{(+2)} = g_{ij}^{(+)} dx^i dx^j \text{ with signature } (+---), \quad (3)$$

$$g_{ij}^{(+)} = \begin{pmatrix} g_{00}^{(+)} & g_{10}^{(+)} & g_{20}^{(+)} & g_{30}^{(+)} \\ g_{01}^{(+)} & g_{11}^{(+)} & g_{21}^{(+)} & g_{31}^{(+)} \\ g_{02}^{(+)} & g_{12}^{(+)} & g_{22}^{(+)} & g_{32}^{(+)} \\ g_{03}^{(+)} & g_{13}^{(+)} & g_{23}^{(+)} & g_{33}^{(+)} \end{pmatrix} \quad (4)$$

is metric tensor of the “outer” side of the $2^3\text{-}\lambda_{m,n}$ -vacuum (i.e. *subcont*) (see Figure 2);

$$ds^{(-+++2)} = ds^{(-2)} = g_{ij}^{(-)} dx^i dx^j \text{ with signature } (-+++), \quad (5)$$

$$g_{ij}^{(-)} = \begin{pmatrix} g_{00}^{(-)} & g_{10}^{(-)} & g_{20}^{(-)} & g_{30}^{(-)} \\ g_{01}^{(-)} & g_{11}^{(-)} & g_{21}^{(-)} & g_{31}^{(-)} \\ g_{02}^{(-)} & g_{12}^{(-)} & g_{22}^{(-)} & g_{32}^{(-)} \\ g_{03}^{(-)} & g_{13}^{(-)} & g_{23}^{(-)} & g_{33}^{(-)} \end{pmatrix} \quad (6)$$

is metric tensor of the “inner” side of the $2^3\text{-}\lambda_{m,n}$ -vacuum (i.e. *antisubcont*) (see Figure 2);

Conditional concepts of "subcont" (short for "substantial continuum") and "antisubcont" (short for "antisubstantial continuum") were introduced in §7 in [2] to designate, respectively, the outer and inner sides of the $2^3\text{-}\lambda_{m,n}$ -vacuum, as well as to facilitate the visualization of intertwined intra-vacuum processes. It is conditionally assumed that the "subcont" is formed from streams (threads) of white color, and the antisubcont is formed from streams (threads) of black color (see Figure 3b and Figure 12 in [3]).

In § 5.2 in [3] it was shown that adjacent segments of the “white” lines $ds^{(+)}$ of the *subcont* and the “black” lines $ds^{(-)}$ of the *antisubcont* are mutually perpendicular $ds^{(+)} \perp ds^{(-)}$ (see Figure 3a). This is possible only if they are everywhere intertwined with each other (Figure 3b), and form a 3-dimensional affine fabric of $2^3\text{-}\lambda_{m,n}$ -vacuum (Figure 3b,c).

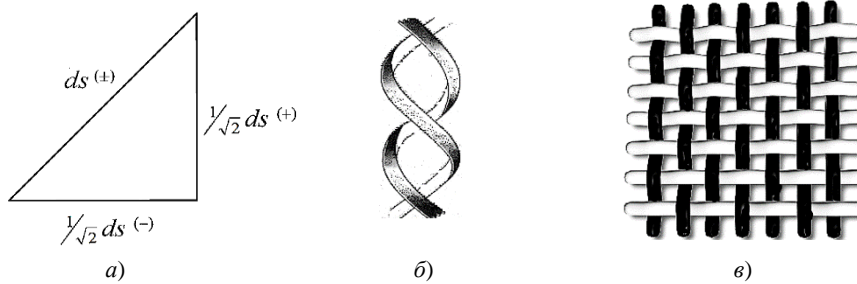

Fig. 3: a) Mutually perpendicular adjacent segments $(\frac{1}{2})^{1/2} ds^{(+)}$ and $(\frac{1}{2})^{1/2} ds^{(-)}$; b) If we project a double helix onto a plane, then at the intersection of its lines $ds^{(+)}$ and $ds^{(-)}$ are always mutually perpendicular (repetition of Figure 10 in [3]); c) Conventionally, the “white” lines of the $ds^{(+)}$ *subcont* and the “black” lines of the $ds^{(-)}$ *antisubcont* form a single intertwined affine fabric of the $2^3\text{-}\lambda_{m,n}$ -vacuum

Thus, the averaged metric (2) corresponds to a segment of a 2-braid consisting of two mutually intertwined spirals $s^{(-)}$ and $s^{(+)}$ (see the definition of a k -braid in § 5.2 in [3]), which can be described by a complex number

$$ds^{(\pm)} = \frac{1}{\sqrt{2}} (ds^{(-)} + i ds^{(+)}), \quad (7)$$

which we will call a 2-helix. The squared modulus of a complex number (7) (i.e., a 2-helix) is equal to the length of a segment of a 2-braid (2) or expression (61) in [3].

Based on the Algebra of Signature presented in [1, 2, 3] and partly repeated in this introduction, this article discusses the general dynamics of vacuum layers, from which, under certain conditions, “vacuum electrodynamics” and “vacuum electrostatics” are obtained.

Like the three previous articles [1, 2, 3], this article is mainly of a theoretical nature and is aimed at further development of the mathematical apparatus of the Algebra of Signature (abbreviated as «Alsigna»).

It is planned that in the following articles of this series, Alsigna’s mathematical apparatus will be used for applied problems, in particular, for the development of a vacuum model of the Universe, a vacuum model of elementary particles, to explain the nature of gravity and electromagnetism, as well as for development of the “zero” (vacuum) technologies.

MATERIALS AND METHOD

1 Equation of the geodesic line of a two-sided 2^3 - $\lambda_{m,n}$ -vacuum

The shortest distance between two infinitely close points p_1 and p_2 in a curved area of a two-sided 2^3 - $\lambda_{m,n}$ -vacuum is defined as an extremal of the functional

$$S = \int_{p_1}^{p_2} ds^{(\pm)}, \quad (8)$$

where $ds^{(\pm)}$ is a 2-helix (7), integration is performed from point p_1 to point p_2 .

We find the equation of this extremal based on the condition that the first variation is equal to zero

$$\delta S = \int_{p_1}^{p_2} ds^{(\pm)} = \delta \int_{p_1}^{p_2} \frac{1}{\sqrt{2}} (ds^{(+)} + id s^{(-)}) = 0. \quad (9)$$

Let’s represent expression (9) in the form

$$\delta S = \frac{1}{\sqrt{2}} \left(\delta \int_{p_1}^{p_2} ds^{(+)} + i \delta \int_{p_1}^{p_2} ds^{(-)} \right) = 0, \quad (10)$$

or taking into account metrics (3) and (5)

$$\delta S = \frac{1}{\sqrt{2}} \left(\sqrt{g_{ij}^{(+)} dx^i dx^j} + i \delta \int_{p_1}^{p_2} \sqrt{g_{ij}^{(-)} dx^i dx^j} \right) = 0. \quad (11)$$

Expression (11) is equal to zero provided that both terms are equal to zero

$$\delta \int_{p_1}^{p_2} \sqrt{g_{ij}^{(+)} dx^i dx^j} = 0 \quad \text{и} \quad \delta \int_{p_1}^{p_2} \sqrt{g_{ij}^{(-)} dx^i dx^j} = 0. \quad (12)$$

In §2 in [3], it was shown that in the most general case, the metric of a local area of a curved 4-dimensional space with any of the 16 possible signatures (22) in [3], can be represented as a scalar product of two vectors given in distorted affine spaces with corresponding signatures (see Expressions (18) – (20) in [3])

$$ds^{(a)2} = ds^{(a)}ds^{(b)} = g_{ij}^{(a)}dx^i dx^j = \beta^{pm(a)}\mathbf{e}_m^{(a)}\alpha_{pi}^{(a)}\beta^{ln(b)}\mathbf{e}_n^{(b)}\alpha_{lj}^{(b)}dx^i dx^j, \quad (13)$$

where

$$ds^{(a)} = \beta^{pm(a)}\mathbf{e}_m^{(a)}\alpha_{pi}^{(a)}dx^i \quad \text{and} \quad ds^{(b)} = \beta^{ln(b)}\mathbf{e}_n^{(b)}\alpha_{lj}^{(b)}dx^j \quad (14)$$

is vectors defined respectively in the a -th and b -th curved affine space with the corresponding signature (see §2 in [3]);

$$\alpha_{ij}^{(a)} = dx^{i(a)}/dx^{j(a)} \quad (15)$$

is components of the elongation tensor of the axes of the curved region of the a -th affine space with the corresponding signature from matrix (2) in [2];

$$\beta^{pm(a)} = (\mathbf{e}_p^{(a)} \cdot \mathbf{e}_m^{(a)}) = \cos(\mathbf{e}_p^{(a)} \wedge \mathbf{e}_m^{(a)}) \quad (16)$$

is direction cosines between the axes of the curved section of the a -th affine space with the same signature;

$\mathbf{e}_m^{(a)}$ is basis vector specifying the direction of the m -th axis of the a -th affine space;

$dx^{j(a)}$ is an infinitesimal segment of the j -th axis of the a -th affine space.

When parallel translation, for example, a vector $ds^{(a)}$ (or a vector $ds^{(b)}$) in a complexly curved, twisted and displaced affine (i.e., vector) space along a geodesic line from point p_1 to a nearby point p_2 (see Figure 4b), it should be taken into account that the magnitude and direction of this vector may depend on changes in all four parameters $\alpha_{ij}^{(a)}$, $\beta^{pm(a)}$, $\mathbf{e}_m^{(a)}$, $dx^{j(a)}$. That is, when translating the vector $ds^{(a)}$ from point p_1 to p_2 , in the most complex case the following may change (see Figure 4b): 1) The length of the basis vectors $\alpha_{ij}^{(a)}$; 2) angles between the basis vectors $\beta^{pm(a)}$; 3) rotation of the entire 4-basis as a whole $\mathbf{e}_m^{(a)}$; 4) Displacement of the 4-basis in general $dx^{j(a)}$. This is due to the fact that the geodesic line between two points p_1 and p_2 of a complexly distorted space can not only be curved, but also deformed, displaced and twisted.

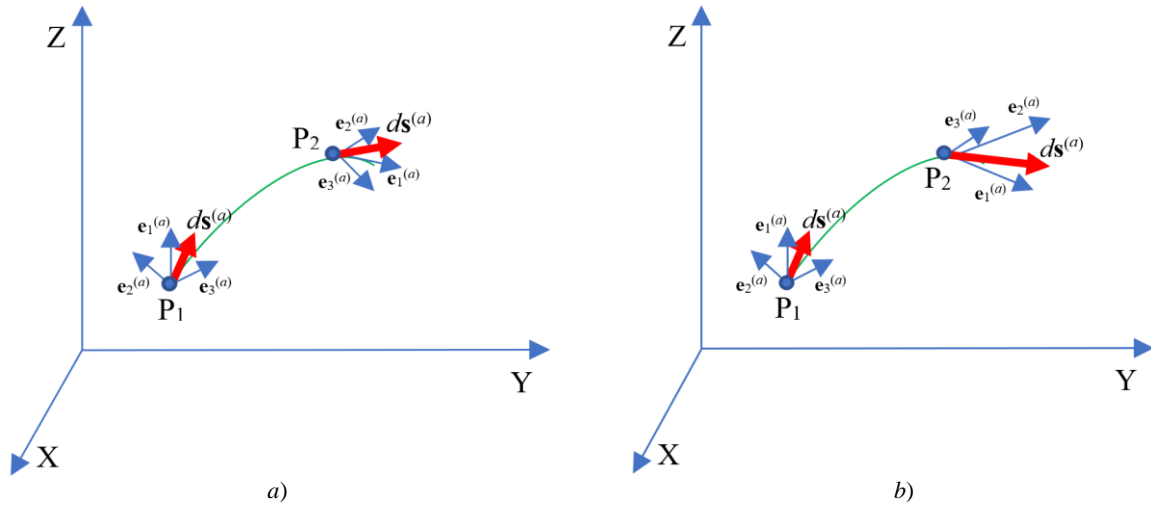

Fig. 4: a) In Riemannian geometry, the parallel translation of the vector $ds^{(a)}$ from point p_1 to the nearby point p_2 is carried out strictly tangent to the geodesic line connecting these points. In this case, only the direction of this vector changes, and its magnitude remains unchanged. It means that the magnitude of the basis vectors $\mathbf{e}_m^{(a)}$ and the angles between them do not change; b) In the most complexly curved, displaced and twisted space, when transferring (i.e. translation) the vector $ds^{(a)}$ from point p_1 to the nearby point p_2 , its direction, magnitude and displacement may change. When transferring the vector $ds^{(a)}$ in such a complexly distorted space, the magnitude of the basis vectors $\mathbf{e}_m^{(a)}$ and the angles between them can change, and the 4-basis itself as a whole can rotate and shift. In this case, all four parameters of the 4-basis $\alpha_{ij}^{(a)}$, $\beta^{pm(a)}$, $\mathbf{e}_m^{(a)}$, $dx^{j(a)}$ can change, which, according to expression (14), affects the change in the vector $ds^{(a)}$ when it is transferred.

Depending on what distortions, displacements and rotations of the vectors $ds^{(a)}$ and $ds^{(b)}$ are taken into account when considering the metric-dynamic properties of curved space, various differential geometries are obtained: for example, Riemannian geometry (see Figure 4a), Weyl geometry, affine geometry of Eddington, geometry with torsion of Cartan-Schouten, geometry of absolute parallelism of Weizenbeck-Vitali-Shipov [4], etc.

1.1 Equation of the geodesic line of a two-sided 2^3 - $\lambda_{m,n}$ -vacuum in the case of Riemannian geometry

First, let's assume that the outer and inner 4-dimensional sides of the 2^3 - $\lambda_{m,n}$ -vacuum (i.e. *subcont* and *antisubcont*) are only curved, i.e. are described by the simplest differential Riemannian geometry (see Figure 4a). In this case, the extremals of functionals (12) are defined identically, so we introduce a generalized metric

$$ds^2 = g_{ij} dx^i dx^j \leftrightarrow \begin{cases} \text{or } ds^{(+2)} = g_{ij}^{(+)} dx^i dx^j, \\ \text{or } ds^{(-2)} = g_{ij}^{(-)} dx^i dx^j. \end{cases}$$

We consider the general case

$$\delta \int_{p_1}^{p_2} ds = \delta \int_{p_1}^{p_2} \sqrt{g_{ij} dx^i dx^j} = 0, \quad (17)$$

provided that at the ends of the desired geodesic line ds (i.e. at points p_1 and p_2) the variations are zero

$$\delta ds_{(p_1)} = \delta ds_{(p_2)} = \delta x_{(p_1)} = \delta x_{(p_2)} = 0. \quad (18)$$

Let's use the expression

$$\delta ds^2 = 2ds\delta ds, \quad (19)$$

whence it follows [5]

$$\delta ds = \frac{1}{2ds} \delta g_{ij} dx^i dx^j = \frac{1}{2ds} \left[\frac{\partial g_{ij}}{\partial x^\mu} \delta x^\mu dx^i dx^j + g_{ij} dx^j d\delta x^i + g_{ij} dx^i d\delta x^j \right], \quad (20)$$

where the commutativity of the operations of variation and differentiation $\delta(dx^i) = d(\delta x^i)$ is used.

Let's substitute Ex. (20) under the integral (17), and divide and multiply this expression by ds , as a result we obtain [5]

$$\delta S = \frac{1}{2} \int_{p_1}^{p_2} \left\{ \frac{\partial g_{ij}}{\partial x^\mu} \frac{dx^i}{ds} \frac{dx^j}{ds} \delta x^\mu + \left(g_{\mu j} \frac{dx^j}{ds} + g_{i\mu} \frac{dx^i}{ds} \right) \frac{d(\delta x^\mu)}{ds} \right\} ds = 0. \quad (21)$$

We integrate the expression in parentheses by parts [5]:

$$\frac{1}{2} \int_{p_1}^{p_2} \left(g_{\mu j} \frac{dx^j}{ds} + g_{i\mu} \frac{dx^i}{ds} \right) \frac{d(\delta x^\mu)}{ds} ds = \frac{1}{2} \left(g_{\mu k} \frac{dx^k}{ds} + g_{i\mu} \frac{dx^i}{ds} \right) \delta x^\mu \Big|_{p_1}^{p_2} - \frac{1}{2} \int_{p_1}^{p_2} \delta x^\mu \frac{d}{ds} \left(g_{\mu j} \frac{dx^j}{ds} + g_{i\mu} \frac{dx^i}{ds} \right) ds. \quad (22)$$

The first term in this expression, due to conditions (18), becomes zero. Let's substitute the remaining part of expression (22) into equation (21) and perform differentiation, as a result we obtain [5]:

$$\delta S = \frac{1}{2} \int_{p_1}^{p_2} \left\{ \left(\frac{\partial g_{ij}}{\partial x^\mu} - \frac{\partial g_{\mu j}}{\partial x^i} - \frac{\partial g_{i\mu}}{\partial x^j} \right) \frac{dx^i}{ds} \frac{dx^j}{ds} + 2g_{\mu j} \frac{d^2 x^j}{ds^2} \right\} ds \delta x^\mu = 0. \quad (23)$$

From the fact that integral (23) vanishes for any variations of δx^μ , it follows that the expression enclosed in curly brackets is equal to zero. From where, taking into account the relation $g_{ij} g^{ij} = 4$, after simple calculations we obtain the equation of the geodesic line [5]:

$$\frac{d^2 x^l}{ds^2} + \Gamma_{ij}^l \frac{dx^i}{ds} \frac{dx^j}{ds} = 0, \quad (24)$$

where $\Gamma_{ij}^l = \frac{1}{2} g^{l\mu} \left(\frac{\partial g_{\mu i}}{\partial x^j} + \frac{\partial g_{\mu j}}{\partial x^i} - \frac{\partial g_{ij}}{\partial x^\mu} \right)$ is Christoffel symbols; (25)

$x^i(s)$ is coordinates of the curved line.

Eq. (24) is intended to determine the extremal of functional (17) with simplifications related to Riemannian geometry (Figure 4a). This equation determines the most optimal (geodesic) line connecting two close points p_1 and p_2 in a curved 4-dimensional space. That is, this is a line that, under the above conditions, allows you to get from point p_1 to the nearby point p_2 in the shortest time and with the least energy costs.

At the same time, Eq. (24) can be represented in the form

$$\frac{d^2 x^l}{ds^2} = -\Gamma_{ij}^l \frac{dx^i}{ds} \frac{dx^j}{ds}, \quad (26)$$

this equation defines the 4-acceleration field $d^2 x^l / ds^2$, which can be interpreted as a massless force field f^l

$$\frac{d^2 x^l}{ds^2} = f^l / m_b,$$

where m_b is the mass of a body that is carried away by a continuous “medium”, which moving with acceleration $d^2 x^l / ds^2$.

At this stage of research, it is difficult to explain what is meant by a force field in vacuum physics. However, it is possible to compare the acceleration of a local section of the vacuum layer with the accelerated movement of a small volume of liquid in the general flow of the river. Such an accelerated flow carries with it everything that comes in its way and makes it move with the same acceleration. From the point of view of post-Newtonian physics, if a body moves with acceleration, then a force acts on it. Therefore, the accelerated movement of the local volume of a 3-dimensional medium (in this case, subcont, or antisubcont) can be interpreted as a local force effect.

Performing separately similar operations (17) – (24) for variations (12), we obtain two equations

$$\frac{d^2 x^l}{ds^2} + \Gamma_{ij}^{l(-)} \frac{dx^i}{ds} \frac{dx^j}{ds} = 0, \quad (27)$$

$$\frac{d^2 x^l}{ds^2} + \Gamma_{ij}^{l(+)} \frac{dx^i}{ds} \frac{dx^j}{ds} = 0, \quad (28)$$

where respectively

$$\Gamma_{ij}^{l(+)} = \frac{1}{2} g^{l\mu(+)} \left(\frac{\partial g_{\mu i}^{(+)}}{\partial x^j} + \frac{\partial g_{\mu j}^{(+)}}{\partial x^i} - \frac{\partial g_{ij}^{(+)}}{\partial x^\mu} \right) \text{ is Christoffel symbols of a } \textit{subcont}; \quad (29)$$

$$\Gamma_{ij}^{l(-)} = \frac{1}{2} g^{l\mu(-)} \left(\frac{\partial g_{\mu i}^{(-)}}{\partial x^j} + \frac{\partial g_{\mu j}^{(-)}}{\partial x^i} - \frac{\partial g_{ij}^{(-)}}{\partial x^\mu} \right) \text{ is Christoffel symbols of a } \textit{antisubcont}. \quad (30)$$

When considering variation (11), taking into account the Christoffel symbols (29) and (30), we find that the sought-for extremal of the functional (8), with simplifications related to Riemannian geometry, is determined by the following equation of a geodesic line in a curved two-sided 2^3 - $\lambda_{m,n}$ -vacuum

$$\frac{d^2 x^l}{ds^2} + \frac{1}{\sqrt{2}} (\Gamma_{ij}^{l(+)} + i\Gamma_{ij}^{l(-)}) \frac{dx^i}{ds} \frac{dx^j}{ds} = 0, \quad (31)$$

or

$$\frac{d^2 x^l}{ds^2} = -\frac{1}{\sqrt{2}} (\Gamma_{ij}^{l(+)} + i\Gamma_{ij}^{l(-)}) \frac{dx^i}{ds} \frac{dx^j}{ds}. \quad (32)$$

Ex. (31) shows that the geodesic lines of the *subcont* and *antisubcont*, i.e. two mutually opposite sides of the local section of the two-sided $2^3\text{-}\lambda_{m,n}$ -vacuum is twisted into a 2-spiral. This is similar to how rivulets twist in a freely falling jet of liquid (see Figure 5).

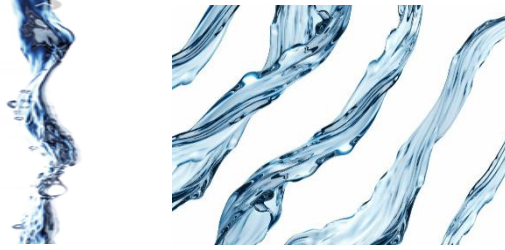

Fig. 5: Many streams in a freely falling stream of liquid twist into a spiral

Continuing the analogy with liquid, it should be noted that within the framework of the Algebra of Signature, a two-sided $2^3\text{-}\lambda_{m,n}$ -vacuum can be represented as an interweaving (mixing) of two liquids (*subcont* and *antisubcont*), which can be conditionally “colored” in white and black colors (see Figure 6). These two conjugate “liquids” cannot separately move in a straight line; they are interconnected and can move in one direction only by twisting into a 2-helix.



Fig. 6: Illustrations of mixing of white and black “liquids”

1.2 Equation of the geodesic line of a 16-sided $2^6\text{-}\lambda_{m,n}$ -vacuum in the case of Riemannian geometry

In the previous paragraph, we considered the most simplified model representation of the interweaving of geodesic lines of a two-sided $2^3\text{-}\lambda_{m,n}$ -vacuum which can be interpreted as mixing and interweaving of flows of two liquids: conventionally “white” and “black”). With a more detailed examination of such conjugate “multi-colored” liquids there should be 16. With an even more detailed examination of these liquids there are already 256 and so on ad infinitum.

More in-depth and accurate is the sixteen-sided consideration of the local area of the $2^6\text{-}\lambda_{m,n}$ -vacuum (see §3 and §5.3 in [3]). In this case, the curved state of the $2^6\text{-}\lambda_{m,n}$ -vacuum is described by a superposition (averaging) not of two, as in the previous paragraph, but of sixteen 4-metrics (see Ex. (25) in [3]).

$$\begin{aligned}
 s_{(16)}^2 = \frac{1}{16} \sum_{q=1}^{16} g_{ij}^{(q)} dx_i dx_j = \frac{1}{16} [& g_{ij}^{(1)} dx^i dx^j + g_{ij}^{(2)} dx^i dx^j + g_{ij}^{(3)} dx^i dx^j + g_{ij}^{(4)} dx^i dx^j + \\
 & + g_{ij}^{(5)} dx^i dx^j + g_{ij}^{(6)} dx^i dx^j + g_{ij}^{(7)} dx^i dx^j + g_{ij}^{(8)} dx^i dx^j + \\
 & + g_{ij}^{(9)} dx^i dx^j + g_{ij}^{(10)} dx^i dx^j + g_{ij}^{(11)} dx^i dx^j + g_{ij}^{(12)} dx^i dx^j + \\
 & + g_{ij}^{(13)} dx^i dx^j + g_{ij}^{(14)} dx^i dx^j + g_{ij}^{(15)} dx^i dx^j + g_{ij}^{(16)} dx^i dx^j] = 0, \tag{33}
 \end{aligned}$$

where

$$g_{ij}^{(q)} = \begin{pmatrix} g_{00}^{(q)} & g_{10}^{(q)} & g_{20}^{(q)} & g_{30}^{(q)} \\ g_{01}^{(q)} & g_{11}^{(q)} & g_{21}^{(q)} & g_{31}^{(q)} \\ g_{02}^{(q)} & g_{12}^{(q)} & g_{22}^{(q)} & g_{32}^{(q)} \\ g_{03}^{(q)} & g_{13}^{(q)} & g_{23}^{(p)} & g_{33}^{(q)} \end{pmatrix} \quad (34)$$

is components of the metric tensor of the q -th metric space with a signature from the matrix (22) in [3]:

$$\text{sign}(g_{ij}^{(q)}) = \begin{pmatrix} (+ + + +)^1 & (+ + + -)^5 & (- + + -)^9 & (+ + - +)^{13} \\ (- - - +)^2 & (- + + +)^6 & (- - + +)^{10} & (- + - +)^{14} \\ (+ - - +)^3 & (+ + - -)^7 & (+ - - -)^{11} & (+ - + +)^{15} \\ (- - + -)^4 & (+ - + -)^8 & (- + - -)^{12} & (- - - -)^{16}. \end{pmatrix} \quad (35)$$

In the framework of the Algebra of Signature, Ex. (33) is called a 16-braid, which is formed by the additive superposition of sixteen 4-dimensional metric spaces (see §5.3 in [3]). In this case, a section of a 16-braid is formed from sixteen intertwined “colored” lines (spiral threads) $ds^{(q)}$, and is described by Ex. (69) in [3]

$$ds_{(16)} = 1/\sqrt{16} (\eta_1 ds^{(+- -)} + \eta_2 ds^{(+++)} + \eta_3 ds^{(---)} + \eta_4 ds^{(+ - -)} + \eta_5 ds^{(- - -)} + \eta_6 ds^{(+ + -)} + \eta_7 ds^{(+ - -)} + \eta_8 ds^{(+ - +)} + \eta_9 ds^{(- + +)} + \eta_{10} ds^{(---)} + \eta_{11} ds^{(+ + +)} + \eta_{12} ds^{(- + -)} + \eta_{13} ds^{(+ + +)} + \eta_{14} ds^{(- - -)} + \eta_{15} ds^{(+ - -)} + \eta_{16} ds^{(- + -)}), \quad (36)$$

where η_m ($m = 1, 2, 3, \dots, 16$) is an orthonormal basis of objects (similar to the imaginary unit i) satisfying the anticommutative Clifford algebra relation (68) in [3]

$$\eta_m \eta_n + \eta_n \eta_m = 2\delta_{mn}, \quad (37)$$

where δ_{nm} is the unit 16×16 matrix.

For example, let's imagine a segment of a 16-helix (36) as a sum of two complex conjugated 8-helices (octonions) with signatures $\{+ - - -\}$ and $\{- + + +\}$

$$ds_{(16)} = 1/\sqrt{2} (ds_{(8)}^{(+)} + ids_{(8)}^{(-)}), \quad (38)$$

where

$$ds_{(8)}^{(+)} = 1/\sqrt{8} (\zeta_1 ds^{(+++)} + \zeta_2 ds^{(+ - -)} + \zeta_3 ds^{(---)} + \zeta_4 ds^{(+ - -)} + \zeta_5 ds^{(- - -)} + \zeta_6 ds^{(+ + -)} + \zeta_7 ds^{(- + -)} + \zeta_8 ds^{(+ - -)}), \quad (39)$$

$$ds_{(8)}^{(-)} = 1/\sqrt{8} (\zeta_1 ds^{(---)} + \zeta_2 ds^{(- + +)} + \zeta_3 ds^{(+++)} + \zeta_4 ds^{(- + -)} + \zeta_5 ds^{(+ + -)} + \zeta_6 ds^{(- - -)} + \zeta_7 ds^{(+ - -)} + \zeta_8 ds^{(- + -)}), \quad (40)$$

where the objects ζ_r (where $r = 1, 2, 3, \dots, 8$), as well as the objects η_m , satisfy the anticommutative relations of the Clifford algebra:

$$\zeta_m \zeta_k + \zeta_k \zeta_m = 2\delta_{km}, \quad (41)$$

where δ_{km} is the Kronecker symbol ($\delta_{km} = 0$ for $m \neq k$ and $\delta_{km} = 1$ for $m = k$).

These requirements are satisfied, for example, by a set of 8×8 matrices of type (65) in [1]:

$$(42)$$

$$\begin{aligned}
\zeta_1 &= \begin{pmatrix} 1 & 0 & 0 & 0 & 0 & 0 & 0 & 0 \\ 0 & 1 & 0 & 0 & 0 & 0 & 0 & 0 \\ 0 & 0 & 1 & 0 & 0 & 0 & 0 & 0 \\ 0 & 0 & 0 & 1 & 0 & 0 & 0 & 0 \\ 0 & 0 & 0 & 0 & 1 & 0 & 0 & 0 \\ 0 & 0 & 0 & 0 & 0 & 1 & 0 & 0 \\ 0 & 0 & 0 & 0 & 0 & 0 & 1 & 0 \\ 0 & 0 & 0 & 0 & 0 & 0 & 0 & 1 \end{pmatrix} & \zeta_2 &= \begin{pmatrix} 0 & 1 & 0 & 0 & 0 & 0 & 0 & 0 \\ -1 & 0 & 0 & 0 & 0 & 0 & 0 & 0 \\ 0 & 0 & 0 & -1 & 0 & 0 & 0 & 0 \\ 0 & 0 & 1 & 0 & 0 & 0 & 0 & 0 \\ 0 & 0 & 0 & 0 & 0 & -1 & 0 & 0 \\ 0 & 0 & 0 & 0 & 1 & 0 & 0 & 0 \\ 0 & 0 & 0 & 0 & 0 & 0 & 0 & 1 \\ 0 & 0 & 0 & 0 & 0 & 0 & -1 & 0 \end{pmatrix} & \zeta_3 &= \begin{pmatrix} 0 & 0 & 1 & 0 & 0 & 0 & 0 & 0 \\ 0 & 0 & 0 & 1 & 0 & 0 & 0 & 0 \\ -1 & 0 & 0 & 0 & 0 & 0 & 0 & 0 \\ 0 & -1 & 0 & 0 & 0 & 0 & 0 & 0 \\ 0 & 0 & 0 & 0 & 0 & 0 & -1 & 0 \\ 0 & 0 & 0 & 0 & 0 & 0 & 0 & -1 \\ 0 & 0 & 0 & 0 & 0 & 1 & 0 & 0 \\ 0 & 0 & 0 & 0 & 0 & 0 & 1 & 0 \end{pmatrix} \\
\zeta_4 &= \begin{pmatrix} 0 & 0 & 0 & 1 & 0 & 0 & 0 & 0 \\ 0 & 0 & -1 & 0 & 0 & 0 & 0 & 0 \\ 0 & 1 & 0 & 0 & 0 & 0 & 0 & 0 \\ -1 & 0 & 0 & 0 & 0 & 0 & 0 & 0 \\ 0 & 0 & 0 & 0 & 0 & 0 & 0 & -1 \\ 0 & 0 & 0 & 0 & 0 & 0 & 1 & 0 \\ 0 & 0 & 0 & 0 & 0 & -1 & 0 & 0 \\ 0 & 0 & 0 & 0 & 1 & 0 & 0 & 0 \end{pmatrix} & \zeta_5 &= \begin{pmatrix} 0 & 0 & 0 & 0 & 1 & 0 & 0 & 0 \\ 0 & 0 & 0 & 0 & 0 & 1 & 0 & 0 \\ 0 & 0 & 0 & 0 & 0 & 0 & 1 & 0 \\ 0 & 0 & 0 & 0 & 0 & 0 & 0 & 1 \\ -1 & 0 & 0 & 0 & 0 & 0 & 0 & 0 \\ 0 & -1 & 0 & 0 & 0 & 0 & 0 & 0 \\ 0 & 0 & -1 & 0 & 0 & 0 & 0 & 0 \\ 0 & 0 & 0 & -1 & 0 & 0 & 0 & 0 \end{pmatrix} & \zeta_6 &= \begin{pmatrix} 0 & 0 & 0 & 0 & 0 & 1 & 0 & 0 \\ 0 & 0 & 0 & 0 & -1 & 0 & 0 & 0 \\ 0 & 0 & 0 & 0 & 0 & 0 & 0 & 1 \\ 0 & 0 & 0 & 0 & 0 & 0 & -1 & 0 \\ 0 & 1 & 0 & 0 & 0 & 0 & 0 & 0 \\ -1 & 0 & 0 & 0 & 0 & 0 & 0 & 0 \\ 0 & 0 & 0 & 1 & 0 & 0 & 0 & 0 \\ 0 & 0 & -1 & 0 & 0 & 0 & 0 & 0 \end{pmatrix} \\
\zeta_7 &= \begin{pmatrix} 0 & 0 & 0 & 0 & 0 & 0 & 1 & 0 \\ 0 & 0 & 0 & 0 & 0 & 0 & 0 & -1 \\ 0 & 0 & 0 & 0 & -1 & 0 & 0 & 0 \\ 0 & 0 & 0 & 0 & 0 & 1 & 0 & 0 \\ 0 & 0 & 1 & 0 & 0 & 0 & 0 & 0 \\ 0 & 0 & 0 & -1 & 0 & 0 & 0 & 0 \\ -1 & 0 & 0 & 0 & 0 & 0 & 0 & 0 \\ 0 & 1 & 0 & 0 & 0 & 0 & 0 & 0 \end{pmatrix} & \zeta_8 &= \begin{pmatrix} 0 & 0 & 0 & 0 & 0 & 0 & 0 & 1 \\ 0 & 0 & 0 & 0 & 0 & 0 & 1 & 0 \\ 0 & 0 & 0 & 0 & 0 & -1 & 0 & 0 \\ 0 & 0 & 0 & 0 & -1 & 0 & 0 & 0 \\ 0 & 0 & 0 & 1 & 0 & 0 & 0 & 0 \\ 0 & 0 & 1 & 0 & 0 & 0 & 0 & 0 \\ 0 & -1 & 0 & 0 & 0 & 0 & 0 & 0 \\ -1 & 0 & 0 & 0 & 0 & 0 & 0 & 0 \end{pmatrix}
\end{aligned}$$

In this case, δ_{km} is a unit 8×8 -matrix:

$$\delta_{km} = \begin{pmatrix} 1 & 0 & 0 & 0 & 0 & 0 & 0 & 0 \\ 0 & 1 & 0 & 0 & 0 & 0 & 0 & 0 \\ 0 & 0 & 1 & 0 & 0 & 0 & 0 & 0 \\ 0 & 0 & 0 & 1 & 0 & 0 & 0 & 0 \\ 0 & 0 & 0 & 0 & 1 & 0 & 0 & 0 \\ 0 & 0 & 0 & 0 & 0 & 1 & 0 & 0 \\ 0 & 0 & 0 & 0 & 0 & 0 & 1 & 0 \\ 0 & 0 & 0 & 0 & 0 & 0 & 0 & 1 \end{pmatrix} \quad (43)$$

Similarly, the objects η_m can be represented by sixteen 16×16 matrices.

Let's look at the functional

$$S = \int_{p_1}^{p_2} ds_{(16)}, \quad (44)$$

where $ds_{(16)}$ is a segment of the 16-helix (36).

Let's equate the first variation of this functional to zero

$$\begin{aligned}
\delta S = & 1/\sqrt{16} (\eta_1 \delta \int ds^{(----)} + \eta_2 \delta \int ds^{(++++)} + \eta_3 \delta \int ds^{(---+)} + \eta_4 \delta \int ds^{(+-+-)} + \\
& + \eta_5 \delta \int ds^{(--++)} + \eta_6 \delta \int ds^{(+--+)} + \eta_7 \delta \int ds^{(----)} + \eta_8 \delta \int ds^{(+-+-)} + \\
& + \eta_9 \delta \int ds^{(----)} + \eta_{10} \delta \int ds^{(----)} + \eta_{11} \delta \int ds^{(++++)} + \eta_{12} \delta \int ds^{(+-+-)} + \\
& + \eta_{13} \delta \int ds^{(+-+-)} + \eta_{14} \delta \int ds^{(----)} + \eta_{15} \delta \int ds^{(+-+-)} + \eta_{16} \delta \int ds^{(+-+-)}) = 0.
\end{aligned} \quad (45)$$

With each term $\eta_q \delta \int_{p_1}^{p_2} ds^{(q)}$ from Ex. (45) we perform operations like (17) – (24), as a result we obtain the extremal equation for a geodesic line in a curved 16-sided 2^6 - $\lambda_{m,n}$ -vacuum

$$\frac{d^2 x^l}{ds^2} + 1/\sqrt{16} (\eta_1 \Gamma_{ij}^{l(1)} + \eta_2 \Gamma_{ij}^{l(2)} + \eta_3 \Gamma_{ij}^{l(3)} + \dots + \eta_{15} \Gamma_{ij}^{l(15)} + \eta_{16} \Gamma_{ij}^{l(16)}) \frac{dx^i}{ds} \frac{dx^j}{ds} = 0, \quad (46)$$

$$\text{or } \frac{d^2 x^l}{ds^2} = -\frac{1}{\sqrt{16}} \left(\sum_{q=1}^{16} \eta_q \Gamma_{ij}^{l(q)} \right) \frac{dx^i}{ds} \frac{dx^j}{ds}, \quad (47)$$

where

$$\Gamma_{ij}^{l(q)} = \frac{1}{2} g^{\mu(q)} \left(\frac{\partial g_{\mu i}^{(q)}}{\partial x^j} + \frac{\partial g_{\mu j}^{(q)}}{\partial x^i} - \frac{\partial g_{ij}^{(q)}}{\partial x^\mu} \right) \quad (48)$$

is Christoffel symbols of the q -th metric space with components of the metric tensor

$$g_{ij}^{(q)} = \begin{pmatrix} g_{00}^{(q)} & g_{10}^{(q)} & g_{20}^{(q)} & g_{30}^{(q)} \\ g_{01}^{(q)} & g_{11}^{(q)} & g_{21}^{(q)} & g_{31}^{(q)} \\ g_{02}^{(q)} & g_{12}^{(q)} & g_{22}^{(q)} & g_{32}^{(q)} \\ g_{03}^{(q)} & g_{13}^{(q)} & g_{23}^{(q)} & g_{33}^{(q)} \end{pmatrix} \quad (49)$$

with the corresponding signature from matrix (35).

Ex. (46) shows that at this level of consideration, the curved area of the 2^6 - $\lambda_{m,n}$ -vacuum is a complex interweaving of the 16-“colored” geodesic lines (see Figure 7). In this case, the 16-strains of the same section of the 2^6 - $\lambda_{m,n}$ -vacuum are described by the strain tensor (63) in [3].

At the same time, the equation of geodesic lines (46) can be represented in the form

$$\frac{d^2 x^l}{ds^2} = -\frac{1}{\sqrt{16}} \left(\sum_{q=1}^{16} \eta_q \Gamma_{ij}^{l(q)} \right) \frac{dx^i}{ds} \frac{dx^j}{ds}, \quad (50)$$

which defines the field of 4-accelerations $d^2 x^l / ds^2$, i.e. total massless force field (see Figure 7)

$$\frac{d^2 x^l}{ds^2} = \frac{1}{\sqrt{16}} \sum_{q=1}^{16} \eta_q \frac{d^2 x^{l(q)}}{ds^2} = f^l / m_b, \quad (51)$$

where m_b is the mass of the body that is carried away by the total (more precisely averaged) accelerated flow.

The next level of consideration is the 2^{10} - $\lambda_{m,n}$ -vacuum, which is considered as the result of the interweaving of not 16, but 256 metric intra-vacuum layers (see §9 in [2] and § 5.3 in [3]). In this case, the curved area of 2^6 - $\lambda_{m,n}$ -vacuum is the result of averaging 265-deformations of the curved area of the 2^{10} - $\lambda_{m,n}$ -vacuum, just as the curved area of the 2^3 - $\lambda_{m,n}$ -vacuum is the result of averaging 16-deformations of the curved area 2^6 - $\lambda_{m,n}$ -vacuum.

A more sophisticated consideration of the curvature of the $\lambda_{m,n}$ -vacuum area can be continued to infinity by a multiple of 2^k (see §9 in [2]). In this case, each time the metric-dynamics of the subsequent transverse level of consideration of the 2^k - $\lambda_{m,n}$ -vacuum is the result of averaging (i.e., in fact, coarsening) of the metric-dynamics of the previous, much more finely and elegantly arranged level 2^{k+1} - $\lambda_{m,n}$ -vacuum.



Fig. 7: Fractal illustration of the interweaving of 16-“colored” geodesic lines, (i.e. accelerated streams or currents) forming the fabric of the 2^6 - $\lambda_{m,n}$ -vacuum

3 Different directions of development of dynamics of a $\lambda_{m,n}$ -vacuum layers

As part of the development of the general dynamics of $\lambda_{m,n}$ -vacuum layers, a number of other possibilities should be considered that may be useful for solving various metric-dynamic problems of geometrized vacuum physics.

The expanded dynamics of a two-sided 2^3 - $\lambda_{m,n}$ -vacuum is based on a functional of the form (8)

$$S = \int_{p_1}^{p_2} ds^{(\pm)} = \frac{1}{\sqrt{2}} \int_{p_1}^{p_2} (ds^{(+)} + i ds^{(-)}),$$

however, the linear forms $ds^{(+)}$ and $ds^{(-)}$ can be represented in different ways, depending on the task and the depth of consideration. Below are several

1). Let's return to the simplest level of consideration of the curved two-sided area of the 2^3 - $\lambda_{m,n}$ -vacuum. In this case, instead of the system of metrics (1), the outer and inner sides (i.e. *subcont* and *antisubcont*) of the curved area of the 2^3 - $\lambda_{m,n}$ -vacuum are described by conjugate metrics

$$\begin{cases} ds^{(+)^2} = g_{ij}^{(+)} dx^i dx^j & \text{with signature } (+ - - -), \\ ds^{(-)^2} = g_{ij}^{(-)} dx^i dx^j & \text{with signature } (- + + +), \end{cases} \quad (52)$$

which, according to Exs. (13) – (14), can be represented as scalar products of vectors $d\mathbf{s}^{(a)}$ and $d\mathbf{s}^{(b)}$

$$\begin{cases} ds^{(+)^2} = d\mathbf{s}^{(a)} d\mathbf{s}^{(b)} & \text{with signature } (+ - - -); \\ ds^{(-)^2} = d\mathbf{s}^{(c)} d\mathbf{s}^{(d)} & \text{with signature } (- + + +), \end{cases} \quad (53)$$

where, for example,

$$\begin{aligned}
d\mathbf{s}^{(a)} &= \beta^{pm(a)} \mathbf{e}_m^{(a)} \alpha_{pi}^{(a)} dx^i && \text{with signature } \{-\ -\ -\ -\} \\
d\mathbf{s}^{(b)} &= \beta^{ln(b)} \mathbf{e}_n^{(b)} \alpha_{lj}^{(b)} dx^j && \text{with signature } \{-\ +\ +\ +\} \\
d\mathbf{s}^{(c)} &= \beta^{pm(c)} \mathbf{e}_m^{(c)} \alpha_{pi}^{(c)} dx^i && \text{with signature } \{+\ +\ +\ +\} \\
d\mathbf{s}^{(d)} &= \beta^{ln(d)} \mathbf{e}_n^{(d)} \alpha_{lj}^{(d)} dx^j && \text{with signature } \{-\ +\ +\ +\}.
\end{aligned} \tag{54}$$

We find variations of all possible binary scalar products of vectors (54)

$$\begin{aligned}
\delta (d\mathbf{s}^{(a)} d\mathbf{s}^{(b)}) &= \delta (d\mathbf{s}^{(a)}) d\mathbf{s}^{(b)} + d\mathbf{s}^{(a)} \delta (d\mathbf{s}^{(b)}) && \text{with signature } (+\ -\ -\ -) \\
\delta (d\mathbf{s}^{(c)} d\mathbf{s}^{(d)}) &= \delta (d\mathbf{s}^{(c)}) d\mathbf{s}^{(d)} + d\mathbf{s}^{(c)} \delta (d\mathbf{s}^{(d)}) && \text{with signature } (-\ +\ +\ +) \\
\delta (d\mathbf{s}^{(a)} d\mathbf{s}^{(c)}) &= \delta (d\mathbf{s}^{(a)}) d\mathbf{s}^{(c)} + d\mathbf{s}^{(a)} \delta (d\mathbf{s}^{(c)}) && \text{with signature } (-\ -\ -\ -) \\
\delta (d\mathbf{s}^{(c)} d\mathbf{s}^{(b)}) &= \delta (d\mathbf{s}^{(c)}) d\mathbf{s}^{(b)} + d\mathbf{s}^{(c)} \delta (d\mathbf{s}^{(b)}) && \text{with signature } (-\ +\ +\ +) \\
\delta (d\mathbf{s}^{(a)} d\mathbf{s}^{(d)}) &= \delta (d\mathbf{s}^{(a)}) d\mathbf{s}^{(d)} + d\mathbf{s}^{(a)} \delta (d\mathbf{s}^{(d)}) && \text{with signature } (+\ -\ -\ -) \\
\delta (d\mathbf{s}^{(d)} d\mathbf{s}^{(b)}) &= \delta (d\mathbf{s}^{(d)}) d\mathbf{s}^{(b)} + d\mathbf{s}^{(d)} \delta (d\mathbf{s}^{(b)}) && \text{with signature } (+\ +\ +\ +).
\end{aligned} \tag{55}$$

Among them there are only four variations with different signatures

$$\begin{aligned}
\delta (d\mathbf{s}^{(c)} d\mathbf{s}^{(d)}) &= \delta (d\mathbf{s}^{(c)}) d\mathbf{s}^{(d)} + d\mathbf{s}^{(c)} \delta (d\mathbf{s}^{(d)}) && \text{with signature } (-\ +\ +\ +) \\
\delta (d\mathbf{s}^{(d)} d\mathbf{s}^{(b)}) &= \delta (d\mathbf{s}^{(d)}) d\mathbf{s}^{(b)} + d\mathbf{s}^{(d)} \delta (d\mathbf{s}^{(b)}) && \text{with signature } (+\ +\ +\ +) \\
\delta (d\mathbf{s}^{(a)} d\mathbf{s}^{(b)}) &= \delta (d\mathbf{s}^{(a)}) d\mathbf{s}^{(b)} + d\mathbf{s}^{(a)} \delta (d\mathbf{s}^{(b)}) && \text{with signature } (+\ -\ -\ -) \\
\delta (d\mathbf{s}^{(a)} d\mathbf{s}^{(c)}) &= \delta (d\mathbf{s}^{(a)}) d\mathbf{s}^{(c)} + d\mathbf{s}^{(a)} \delta (d\mathbf{s}^{(c)}) && \text{with signature } (-\ -\ -\ -).
\end{aligned} \tag{56}$$

We equate the variations of the following functionals to zero

$$\begin{aligned}
\delta \int d\mathbf{s}^{(a)} &= \delta \int \beta^{pm(a)} \mathbf{e}_m^{(a)} \alpha_{pi}^{(a)} dx^i = \int (\delta \beta^{pm(a)} \mathbf{e}_m^{(a)} \alpha_{pi}^{(a)} dx^i + \beta^{pm(a)} \delta \mathbf{e}_m^{(a)} \alpha_{pi}^{(a)} dx^i + \beta^{pm(a)} \mathbf{e}_m^{(a)} \delta \alpha_{pi}^{(a)} dx^i + \beta^{pm(a)} \mathbf{e}_m^{(a)} \alpha_{pi}^{(a)} \delta dx^i) = 0, \\
\delta \int d\mathbf{s}^{(b)} &= \delta \int \beta^{ln(b)} \mathbf{e}_n^{(b)} \alpha_{lj}^{(b)} dx^j = \int (\delta \beta^{ln(b)} \mathbf{e}_n^{(b)} \alpha_{lj}^{(b)} dx^j + \beta^{ln(b)} \delta \mathbf{e}_n^{(b)} \alpha_{lj}^{(b)} dx^j + \beta^{ln(b)} \mathbf{e}_n^{(b)} \delta \alpha_{lj}^{(b)} dx^j + \beta^{ln(b)} \mathbf{e}_n^{(b)} \alpha_{lj}^{(b)} \delta dx^j) = 0, \\
\delta \int d\mathbf{s}^{(c)} &= \delta \int \beta^{pm(c)} \mathbf{e}_m^{(c)} \alpha_{pi}^{(c)} dx^i = \int (\delta \beta^{pm(c)} \mathbf{e}_m^{(c)} \alpha_{pi}^{(c)} dx^i + \beta^{pm(c)} \delta \mathbf{e}_m^{(c)} \alpha_{pi}^{(c)} dx^i + \beta^{pm(c)} \mathbf{e}_m^{(c)} \delta \alpha_{pi}^{(c)} dx^i + \beta^{pm(c)} \mathbf{e}_m^{(c)} \alpha_{pi}^{(c)} \delta dx^i) = 0, \\
\delta \int d\mathbf{s}^{(d)} &= \delta \int \beta^{ln(d)} \mathbf{e}_n^{(d)} \alpha_{lj}^{(d)} dx^j = \int (\delta \beta^{ln(d)} \mathbf{e}_n^{(d)} \alpha_{lj}^{(d)} dx^j + \beta^{ln(d)} \delta \mathbf{e}_n^{(d)} \alpha_{lj}^{(d)} dx^j + \beta^{ln(d)} \mathbf{e}_n^{(d)} \delta \alpha_{lj}^{(d)} dx^j + \beta^{ln(d)} \mathbf{e}_n^{(d)} \alpha_{lj}^{(d)} \delta dx^j) = 0.
\end{aligned} \tag{57}$$

Ex. (57) can be represented as

$$\begin{aligned}
\delta \int d\mathbf{s}^{(a)} &= \int \delta \beta^{pm(a)} \mathbf{e}_m^{(a)} \alpha_{pi}^{(a)} dx^i + \int \beta^{pm(a)} \delta \mathbf{e}_m^{(a)} \alpha_{pi}^{(a)} dx^i + \int \beta^{pm(a)} \mathbf{e}_m^{(a)} \delta \alpha_{pi}^{(a)} dx^i + \int \beta^{pm(a)} \mathbf{e}_m^{(a)} \alpha_{pi}^{(a)} \delta dx^i = 0, \\
\delta \int d\mathbf{s}^{(b)} &= \int \delta \beta^{ln(b)} \mathbf{e}_n^{(b)} \alpha_{lj}^{(b)} dx^j + \int \beta^{ln(b)} \delta \mathbf{e}_n^{(b)} \alpha_{lj}^{(b)} dx^j + \int \beta^{ln(b)} \mathbf{e}_n^{(b)} \delta \alpha_{lj}^{(b)} dx^j + \int \beta^{ln(b)} \mathbf{e}_n^{(b)} \alpha_{lj}^{(b)} \delta dx^j = 0, \\
\delta \int d\mathbf{s}^{(c)} &= \int \delta \beta^{pm(c)} \mathbf{e}_m^{(c)} \alpha_{pi}^{(c)} dx^i + \int \beta^{pm(c)} \delta \mathbf{e}_m^{(c)} \alpha_{pi}^{(c)} dx^i + \int \beta^{pm(c)} \mathbf{e}_m^{(c)} \delta \alpha_{pi}^{(c)} dx^i + \int \beta^{pm(c)} \mathbf{e}_m^{(c)} \alpha_{pi}^{(c)} \delta dx^i = 0, \\
\delta \int d\mathbf{s}^{(d)} &= \int \delta \beta^{ln(d)} \mathbf{e}_n^{(d)} \alpha_{lj}^{(d)} dx^j + \int \beta^{ln(d)} \delta \mathbf{e}_n^{(d)} \alpha_{lj}^{(d)} dx^j + \int \beta^{ln(d)} \mathbf{e}_n^{(d)} \delta \alpha_{lj}^{(d)} dx^j + \int \beta^{ln(d)} \mathbf{e}_n^{(d)} \alpha_{lj}^{(d)} \delta dx^j = 0.
\end{aligned} \tag{58}$$

Here, all possible changes (distortions, deformations and displacements) of the 4-bases $\mathbf{e}_m^{(a)}$, for example, those shown in Figure 4b.

Substituting variations (58) into Exs. (56), and finding equations for the extremals of these functionals, we obtain 32 types of different accelerations (or massless force effects).

2). In §10 in [2], the spintensor representation of metrics with various signatures was considered.

For example, let's write the diagonal quadratic form with the signature (+ ---) in the following form

$$ds^{(+)} = g_{00}dx^0dx^0 - g_{11}dx^1dx^1 - g_{22}dx^2dx^2 - g_{33}dx^3dx^3 = \begin{pmatrix} q_0dx^0 + q_3dx^3 & q_1dx^1 + iq_2dx^2 \\ q_1dx^1 - iq_0dx^0 & q_0dx^0 - q_3dx^3 \end{pmatrix}_{det}, \quad (59)$$

where $q_i = \sqrt{g_{ii}}$.

This A4 matrix can be represented as a linear form

$$A_4^{(+---)} = \begin{pmatrix} q_0dx^0 + q_3dx^3 & q_1dx^1 + iq_2dx^2 \\ q_1dx^1 - iq_0dx^0 & q_0dx^0 - q_3dx^3 \end{pmatrix} = q_0dx^0 \begin{pmatrix} 1 & 0 \\ 0 & 1 \end{pmatrix} - q_1dx^1 \begin{pmatrix} 0 & -1 \\ -1 & 0 \end{pmatrix} - q_2dx^2 \begin{pmatrix} 0 & -i \\ i & 0 \end{pmatrix} - q_3dx^3 \begin{pmatrix} -1 & 0 \\ 0 & 1 \end{pmatrix}. \quad (60)$$

In this case, the dynamics of a 2^3 - $\lambda_{m,n}$ -vacuum layer with signature (+ ---) can be determined by the equality to zero of the first variation of the functional of the form

$$\delta \int_{p_1}^{p_2} A_4^{(+---)} = \delta \int_{p_1}^{p_2} \left(q_0dx^0 \begin{pmatrix} 1 & 0 \\ 0 & 1 \end{pmatrix} - q_1dx^1 \begin{pmatrix} 0 & -1 \\ -1 & 0 \end{pmatrix} - q_2dx^2 \begin{pmatrix} 0 & -i \\ i & 0 \end{pmatrix} - q_3dx^3 \begin{pmatrix} -1 & 0 \\ 0 & 1 \end{pmatrix} \right) = 0, \quad (61)$$

The dynamics of all other 2^3 - $\lambda_{m,n}$ -vacuum layers are determined similarly (see Table 1 in §10 in [2]) with all possible signatures from matrix (35).

3). In §12 in [2] the Dirac representation of a diagonal quadratic form is considered, for example, with signature (+ + + +)

$$ds^2 = g_{00}dx^0dx^0 + g_{11}dx^1dx^1 + g_{22}dx^2dx^2 + g_{33}dx^3dx^3 \quad (62)$$

as a product of two affine (linear) forms

$$ds^2 = ds'ds'' = (\gamma_0q_0dx^{0'} + \gamma_1q_1dx^{1'} + \gamma_2q_2dx^{2'} + \gamma_3q_3dx^{3'}) \cdot (\gamma_0q_0dx^{0''} + \gamma_1q_1dx^{1''} + \gamma_2q_2dx^{2''} + \gamma_3q_3dx^{3''}), \quad (63)$$

where

$$q_i = \sqrt{g_{ii}};$$

γ_μ is objects satisfying the anticommutative relation of the Clifford algebra

$$\gamma_\mu\gamma_\eta + \gamma_\eta\gamma_\mu = 2\delta_{\mu\eta}. \quad (64)$$

Condition (64) is satisfied, for example, by the following set of 4x4-Dirac matrices:

$$\gamma_0 = \begin{pmatrix} 1 & 0 & 0 & 0 \\ 0 & 1 & 0 & 0 \\ 0 & 0 & -1 & 0 \\ 0 & 0 & 0 & -1 \end{pmatrix}, \quad \gamma_1 = \begin{pmatrix} 0 & 0 & 0 & 1 \\ 0 & 0 & 1 & 0 \\ 0 & 1 & 0 & 0 \\ 1 & 0 & 0 & 0 \end{pmatrix}, \quad \gamma_2 = \begin{pmatrix} 0 & 0 & 0 & -i \\ 0 & 0 & i & 0 \\ 0 & -i & 0 & 0 \\ i & 0 & 0 & 0 \end{pmatrix}, \quad \gamma_3 = \begin{pmatrix} 0 & 0 & 1 & 0 \\ 0 & 0 & 0 & -1 \\ 1 & 0 & 0 & 0 \\ 0 & -1 & 0 & 0 \end{pmatrix}, \quad \delta_{\mu\eta} = \begin{pmatrix} 1 & 0 & 0 & 0 \\ 0 & 1 & 0 & 0 \\ 0 & 0 & 1 & 0 \\ 0 & 0 & 0 & 1 \end{pmatrix}.$$

Also, the diagonal quadratic form (62) with signature (+ + + +) can be represented as

$$ds \equiv \sqrt{(ds_{ii}^2)} = \begin{pmatrix} \sqrt{ds_{00}^2} & 0 & 0 & 0 \\ 0 & \sqrt{ds_{11}^2} & 0 & 0 \\ 0 & 0 & \sqrt{ds_{22}^2} & 0 \\ 0 & 0 & 0 & \sqrt{ds_{33}^2} \end{pmatrix} = \sqrt{\frac{1}{2} \sum_{\mu=0}^3 \sum_{\nu=0}^3 (\gamma_{\mu} \gamma_{\nu} + \gamma_{\nu} \gamma_{\mu}) dx^{\mu} dx^{\nu}}. \quad (65)$$

The variation of the product of two linear forms (63) is equal to

$$\delta(ds' ds'') = \delta(ds') ds'' + ds' \delta(ds''). \quad (66)$$

In this case, the dynamics of a 2^3 - $\lambda_{m,n}$ -vacuum layer with signature $(+++)$ is determined by the system of equations

$$\begin{cases} \delta(ds') = \delta(\gamma_0 q_0 dx^{0'} + \gamma_1 q_2 dx^{1'} + \gamma_2 q_2 dx^{2'} + \gamma_3 q_3 dx^{3'}) = 0, \\ \delta(ds'') = \delta(\gamma_0 q_0 dx^{0''} + \gamma_1 q_2 dx^{1''} + \gamma_2 q_2 dx^{2''} + \gamma_3 q_3 dx^{3''}) = 0. \end{cases} \quad (67)$$

The dynamics of all other 2^3 - $\lambda_{m,n}$ -vacuum layers with all possible signatures (35) are determined similarly, see §12 in [2].

Further development of various options for the dynamics of vacuum layers, based on different methods of representing quadratic forms with different signatures (35) in the form of two linear forms with different signatures (3) in [1] can significantly enrich the mathematical apparatus of the Algebra of Signature for describing complex intra-vacuum structures and processes. Perhaps these areas of the calculus of variations will interest mathematicians with the hope that they will be in demand by physicists.

Looking significantly ahead, we note that for the geometrization of most branches of modern physics based on the Algebra of Signatures, simplifications related to Riemannian geometry (see Figure 4a) are sufficient. This will be shown in the following articles of this series. However, to geometrize psychophysical phenomena, it is necessary to develop the most complex version of differential geometry: – the geometry of absolute parallelism (see Figure 4b) [4, 6] with using the Algebra of Signature, i.e. taking into account the totality of distortions of all 16 types of affine spaces with different stignatures (3) in [1]

$$stign(e_i^{(a)}) = \begin{pmatrix} \{++++\} & \{+++-\} & \{-++-\} & \{+-+ \} \\ \{- - - +\} & \{- + + +\} & \{- - + +\} & \{- + - +\} \\ \{+ - - +\} & \{+ + - -\} & \{+ - - -\} & \{+ - + +\} \\ \{- - + -\} & \{+ - + -\} & \{- + - -\} & \{- - - -\} \end{pmatrix}. \quad (68)$$

4 Dynamics of a two-sided 2^3 - $\lambda_{m,n}$ -vacuum in a state of constant curvature

4.1 Stationary metric in Riemannian geometry

Let's continue considering metrics (52)

$$\begin{cases} ds^{(+2)} = g_{ij}^{(+)} dx^i dx^j \text{ with signature } (+ - - -) \text{ – metric of } \textit{subcont} \text{ (outer side of a } 2^3\text{-} \lambda_{m,n}\text{-vacuum)}, \\ ds^{(-2)} = g_{ij}^{(-)} dx^i dx^j \text{ with signature } (- + + +) \text{ – metric of } \textit{antibsubcont} \text{ (inner side of a } 2^3\text{-} \lambda_{m,n}\text{-vacuum)}. \end{cases} \quad (69)$$

Everything described below applies to both metrics (69) separately, so we investigate the general case

$$ds^2 = g_{ij}dx^i dx^j \leftrightarrow \begin{cases} \text{or } ds^{(+)^2} = g_{ij}^{(+)} dx^i dx^j, \\ \text{or } ds^{(-)^2} = g_{ij}^{(-)} dx^i dx^j. \end{cases} \quad (70)$$

Further in this paragraph we will partially repeat the derivation of several equations from the classical source [5, pp. 250 – 251] due to the fact that these equations are of particular importance for the vacuum dynamics developed here. In addition, the order of presentation has been expanded and changed, and a slightly different interpretation of the results obtained has been proposed.

We assume that all components of the metric tensor in metric (70) are independent of time

$$g_{ij} = \text{const.} \quad (71)$$

Let's rewrite the quadratic form (70), highlighting the components with zero indices

$$ds^2 = c^2 g_{00} dt^2 + 2c g_{0\alpha} dx^\alpha dt + g_{\alpha\beta} dx^\alpha dx^\beta \leftrightarrow \begin{cases} \text{or } ds^{(+)^2} = g_{00}^{(+)} (dx^0)^2 + 2g_{0\alpha}^{(+)} dx^0 dx^\alpha + g_{\alpha\beta}^{(+)} dx^\alpha dx^\beta, \\ \text{or } ds^{(-)^2} = g_{00}^{(-)} (dx^0)^2 + 2g_{0\alpha}^{(-)} dx^0 dx^\alpha + g_{\alpha\beta}^{(-)} dx^\alpha dx^\beta, \end{cases} \quad (72)$$

where $\alpha, \beta = 1, 2, 3; dx^0 = cdt$.

4.2 Velocity of a local region of metric space

Let's determine the speed of movement of a local region of the metric space (in particular, *subcont* or *antisubcont*), the metric-dynamic properties of which are determined by the stationary metric (72).

To do this, to the right side of the generalized metric (72) we add and subtract the quantity

$$\left(\frac{g_{0\alpha} dx^\alpha}{\sqrt{g_{00}}} \right)^2 = \frac{g_{0\alpha} g_{0\beta}}{g_{00}} dx^\alpha dx^\beta, \quad (73)$$

as a result, we get

$$ds^2 = c^2 \left[\sqrt{g_{00}} dt + \frac{g_{0\alpha} dx^\alpha}{c\sqrt{g_{00}}} \right]^2 - \left[-g_{\alpha\beta} + \frac{g_{0\alpha} g_{0\beta}}{g_{00}} \right] dx^\alpha dx^\beta, \quad (74)$$

whence for the studied area of space we have an analogue of proper time [5]

$$d\tau = \sqrt{g_{00}} dt + \frac{g_{0\alpha} dx^\alpha}{c\sqrt{g_{00}}} \quad \text{or} \quad d\tau = \frac{\sqrt{g_{00}}}{c} \left(dx^0 + \frac{g_{0\alpha}}{g_{00}} dx^\alpha \right). \quad (75)$$

The second term in Ex. (74) is the square of the distance between two points in a 3-dimensional metric space (in this case, in a 3-dimensional *subcont* or in a 3-dimensional *antisubcont*)

$$dl^2 = - \left[g_{\alpha\beta} - \frac{g_{0\alpha} g_{0\beta}}{g_{00}} \right] dx^\alpha dx^\beta \quad \text{or} \quad dl^2 = \gamma_{\alpha\beta} dx^\alpha dx^\beta, \quad (76)$$

where the 3-dimensional spatial metric tensor is introduced

$$\gamma_{\alpha\beta} = -g_{\alpha\beta} + \frac{g_{0\alpha} g_{0\beta}}{g_{00}}. \quad (77)$$

Metric (74) taking into account Exs. (75) and (76) takes the form

$$ds^2 = c^2 d\tau^2 - dl^2, \quad (78)$$

which corresponds to the reference system in which the local area under study of one of the sides of the $2^3\text{-}\lambda_{m,n}$ -vacuum (in particular, *subcont* or *antisubcont*) is at rest.

Now we can introduce the 3-dimensional speed of movement of a local region of the metric space (in this case, *subcont* or *antisubcont*), the metric-dynamic properties of which are specified by the components of the metric tensor from metric (72). We divide the distance (76) by the time (75), as a result we obtain the modulus of the velocity vector

$$|\vec{v}| = \frac{dl}{d\tau} = \frac{cdl}{\sqrt{g_{00}}\left(x^0 + \frac{g_{0\alpha}}{g_{00}}dx^\alpha\right)} = \frac{c\sqrt{\left(-g_{\alpha\beta} + \frac{g_{0\alpha}g_{0\beta}}{g_{00}}\right)dx^\alpha dx^\beta}}{\sqrt{g_{00}}\left(x^0 + \frac{g_{0\alpha}}{g_{00}}dx^\alpha\right)} \quad (79)$$

with components [5, p. 250]

$$v^\alpha = \frac{cdx^\alpha}{\sqrt{g_{00}}\left(x^0 + \frac{g_{0\alpha}}{g_{00}}dx^\alpha\right)}. \quad (80)$$

The covariant components of the velocity vector v_α are determined by the Expressions [5, p. 250]

$$v_\alpha = \gamma_{\alpha\beta}v^\beta, \quad v^2 = v_\alpha v^\alpha,$$

Taking into account Ex. (79), the stationary metric (72) can be represented as [5, p. 250]

$$ds^2 = g_{00}(dx^0 - g_\alpha dx^\alpha)^2 \left(1 - \frac{v^2}{c^2}\right), \quad (81)$$

where the 3-dimensional vector is introduced

$$g_\alpha = -\frac{g_{0\alpha}}{g_{00}}. \quad (82)$$

The 4-speed components $u^i = \frac{dx^i}{ds}$, taking into account Ex. (81) are equal [5, p. 251]

$$u^0 = \frac{1}{\sqrt{g_{00}}\sqrt{1 - \frac{v^2}{c^2}}} + \frac{g_\alpha v^\alpha}{c\sqrt{1 - \frac{v^2}{c^2}}}, \quad u^\alpha = \frac{v^\alpha}{c\sqrt{1 - \frac{v^2}{c^2}}}. \quad (83)$$

4.3 Acceleration of a local region of metric space

Let's find the acceleration of a local region of the metric space (in particular, *subcont* or *antisubcont*), the metric-dynamic properties of which are determined by the stationary metric (72).

As was shown in §1.1, the acceleration of a local region of the metric space with simplifications related to Riemannian geometry is given by Eq. (26)

$$\frac{d^2 x^l}{ds^2} = -\Gamma_{ij}^l \frac{dx^i}{ds} \frac{dx^j}{ds}, \quad (84)$$

We find Christoffel symbols (25)

$$\Gamma_{ij}^l = \frac{1}{2} g^{l\mu} \left(\frac{\partial g_{\mu i}}{\partial x^j} + \frac{\partial g_{\mu j}}{\partial x^i} - \frac{\partial g_{ij}}{\partial x^\mu} \right) \quad (85)$$

for the considered stationary case.

Let's substitute the components of the metric tensor from the stationary metric (72) into Ex. (85). As a result, taking into account conditions (71), we obtain the following non-zero components of this pseudotensor [5, p. 251]

$$\Gamma_{00}^\alpha = \frac{1}{2} g_{00}^{;\alpha}, \quad (86)$$

$$\Gamma_{0\beta}^\alpha = \frac{1}{2} g_{00} (g_{;\beta}^\alpha - g_{\beta}^{;\alpha}) - \frac{1}{2} g_{\beta} g_{00}^{;\alpha}, \quad (87)$$

$$\Gamma_{\beta\gamma}^\alpha = \lambda_{\beta\gamma}^\alpha + \frac{1}{2} g_{00} [g_{\beta} (g_{\gamma}^{;\alpha} - g_{;\gamma}^\alpha) + g_{\gamma} (g_{\beta}^{;\alpha} - g_{;\beta}^\alpha)] + \frac{1}{2} g_{\beta} g_{\gamma} g_{00}^{;\alpha}, \quad (88)$$

where, for example, $g_{\gamma}^{;\alpha}$ is the covariant derivative, which in this case coincides with the partial derivative [4]:

$$g_{;\gamma}^\alpha = \frac{\partial g^\alpha}{\partial x^\gamma} + \Gamma_{k\gamma}^\alpha g^k = \frac{\partial g^\alpha}{\partial x^\gamma}, \quad (89)$$

$\lambda_{\beta\gamma}^\alpha$ is a 3-dimensional Christoffel symbol composed of components of the metric tensor $g_{\alpha\beta}$ in the same way as Γ_{ij}^l is composed of components g_{ij} .

In Ex. (86) – (89) all tensor actions (covariant differentiation, raising and lowering indices) are performed in a 3-dimensional space with a metric $g_{\alpha\beta}$ over a 3-dimensional vector g_α and a scalar g_{00} .

Let's substitute Ex. (86) – (89) into the equation of motion (84), as a result we obtain [5, p. 251]

$$\frac{du^\alpha}{ds} = -\Gamma_{00}^\alpha (u^0)^2 - 2\Gamma_{0\beta}^\alpha u^0 u^\beta - \Gamma_{\beta\gamma}^\alpha u^\beta u^\gamma. \quad (90)$$

After transforming Ex. (90) using 4-speed components (83) and Christoffel symbols (86) – (89), we obtain [5, p. 251]

$$\frac{du^\alpha}{ds} = \frac{d}{ds} \frac{v^\alpha}{c \sqrt{1 - \frac{v^2}{c^2}}} = -\frac{g_{00}^{;\alpha}}{2g_{00} \left(1 - \frac{v^2}{c^2}\right)} - \frac{\sqrt{g_{00}} (g_{;\beta}^\alpha - g_{\beta}^{;\alpha}) v^\beta}{c \left(1 - \frac{v^2}{c^2}\right)} - \frac{\lambda_{\beta\gamma}^\alpha v^\beta v^\gamma}{c^2 \left(1 - \frac{v^2}{c^2}\right)}. \quad (91)$$

In the general theory of relativity, based on Riemannian geometry, the force acting on a particle with momentum $\mathbf{p} = m\mathbf{v}$ (where m is the mass of the particle, \mathbf{v} is the speed of the flow entraining the particle) is defined as a 3-dimensional covariant differential [5, p. 251].

$$f^\alpha = c \sqrt{1 - \frac{v^2}{c^2}} \frac{Dp^\alpha}{ds} = c \sqrt{1 - \frac{v^2}{c^2}} \frac{d}{ds} \frac{mv^\alpha}{\sqrt{1 - \frac{v^2}{c^2}}} + \lambda_{\beta\gamma}^\alpha \frac{mv^\beta v^\gamma}{\sqrt{1 - \frac{v^2}{c^2}}}. \quad (92)$$

Let's divide the components of the force vector (92) by the particle mass m . As a result, we obtain the rooms of the acceleration vector of the local region of the metric space (in particular, *subcont* or *antisubcont*)

$$\frac{f^\alpha}{m} = a^\alpha = c \sqrt{1 - \frac{v^2}{c^2}} \frac{d}{ds} \frac{v^\alpha}{\sqrt{1 - \frac{v^2}{c^2}}} + \frac{\lambda_{\beta\gamma}^\alpha v^\beta v^\gamma}{\sqrt{1 - \frac{v^2}{c^2}}}. \quad (93)$$

components of the acceleration vector (93), taking into account Ex. (91), can be represented in the form (for convenience, the index α is omitted) [5, p. 252]

$$a_\alpha = \frac{c^2}{\sqrt{1-\frac{v^2}{c^2}}} \left\{ -\frac{\partial \ln \sqrt{g_{00}}}{\partial x^\alpha} + \sqrt{g_{00}} \left(\frac{\partial g_\beta}{\partial x^\alpha} - \frac{\partial g_\alpha}{\partial x^\beta} \right) \frac{v^\beta}{c} \right\}, \quad (94)$$

or in conventional three-dimensional vector notation [5, p. 252]

$$\vec{a} = \frac{c^2}{\sqrt{1-\frac{v^2}{c^2}}} \left\{ -\text{grad}(\ln \sqrt{g_{00}}) + \sqrt{g_{00}} \left[\frac{\vec{v}}{c} \times \text{rot} \vec{g} \right] \right\}, \quad (95)$$

where $\vec{g}(g_1, g_2, g_3)$ is a 3-dimensional vector with components

$$g_\alpha = -\frac{g_{0\alpha}}{g_{00}}. \quad (96)$$

In the note by Landau L.D. and Lifshits E.M. noted that in three-dimensional curvilinear coordinates $\text{rot} \vec{g}$ should be understood in the same sense as the vector dual to the tensor $\left(\frac{\partial g_\beta}{\partial x^\alpha} - \frac{\partial g_\alpha}{\partial x^\beta} \right)$, so that its contravariant components should be written in the form [5, p. 252]

$$(\text{rot} \vec{g})^\gamma = \frac{1}{2\sqrt{\gamma}} e^{\alpha\beta\gamma} \left(\frac{\partial g_\beta}{\partial x^\alpha} - \frac{\partial g_\alpha}{\partial x^\beta} \right), \quad (97)$$

where $\sqrt{\gamma}$ is the determinant of the spatial metric tensor (77);
 $e^{\alpha\beta\gamma} = e^{123} = e_{123} = 1$, and when two symbols are rearranged, the sign changes.

$$\vec{v} = \frac{d\vec{l}}{d\tau} = \frac{cd\vec{l}}{\sqrt{g_{00}}(dx^0 + \frac{g_{0\alpha}}{g_{00}}dx^\alpha)} \quad (98)$$

is vector of the 3-dimensional velocity of a local region of a metric space (in particular, *subcont* or *antisubcont*) with components (80)

$$v^1 = \frac{cdx^1}{\sqrt{g_{00}}(x^0 + \frac{g_{01}}{g_{00}}dx^1)}, \quad v^2 = \frac{cdx^2}{\sqrt{g_{00}}(x^0 + \frac{g_{02}}{g_{00}}dx^2)}, \quad v^3 = \frac{cdx^3}{\sqrt{g_{00}}(x^0 + \frac{g_{03}}{g_{00}}dx^3)}. \quad (99)$$

We note once again that the formula for the acceleration vector (95) was borrowed from the classical source [5, pp. 250 – 251], where it was obtained within the framework of Riemannian geometry (see Figure 4a), and under the condition that the metric is stationary (72), i.e. when the components of the metric tensor are independent of time (71) $g_{ij} = \text{const}$.

4.4 Acceleration of a local section of 2^3 - $\lambda_{m,n}$ -vacuum

If we perform all operations (71) – (98) separately with each of the metrics (69), we obtain two acceleration vectors:

$$\mathbf{a}^{(+)} = \vec{a}^{(+)} = \frac{c^2}{\sqrt{1-\frac{v^{(+)^2}}{c^2}}} \left\{ -\text{grad} \left(\ln \sqrt{g_{00}^{(+)}} \right) + \sqrt{g_{00}^{(+)}} \left[\frac{\vec{v}^{(+)}}{c} \times \text{rot} \vec{g}^{(+)} \right] \right\} \quad (100)$$

is acceleration vector of the local region of the *subcont* (i.e., the outer side of the 2^3 - $\lambda_{m,n}$ -vacuum);

$$\mathbf{a}^{(-)} = \vec{a}^{(-)} = \frac{c^2}{\sqrt{1-\frac{v^{(-)^2}}{c^2}}} \left\{ -\text{grad} \left(\ln \sqrt{g_{00}^{(-)}} \right) + \sqrt{g_{00}^{(-)}} \left[\frac{\vec{v}^{(-)}}{c} \times \text{rot} \vec{g}^{(-)} \right] \right\} \quad (101)$$

is acceleration vector of the local region of the *antisubcont* (i.e., the inner side of the 2^3 - $\lambda_{m,n}$ -vacuum).

Acceleration of a local region of the 2^3 - $\lambda_{m,n}$ -vacuum (32)

$$\frac{d^2 x^l}{ds^2} = -\frac{1}{\sqrt{2}} \left(\Gamma_{ij}^{l(+)} \frac{dx^i}{ds} \frac{dx^j}{ds} + i \Gamma_{ij}^{l(-)} \frac{dx^i}{ds} \frac{dx^j}{ds} \right), \quad (102)$$

can be represented in the form

$$a^{(\pm)l} = \frac{1}{\sqrt{2}} (a^{(+l)} + i a^{(-l)}), \quad (103)$$

or with indexes omitted

$$a_{\alpha}^{(\pm)} = \frac{1}{\sqrt{2}} (a_{\alpha}^{(+)} + i a_{\alpha}^{(-)}), \quad (104)$$

where in the stationary case under consideration, according to Ex. (94),

$$a_{\alpha}^{(+)} = \frac{c^2}{\sqrt{1-\frac{v^{(+)^2}}{c^2}}} \left\{ -\frac{\partial \ln \sqrt{g_{00}^{(+)}}}{\partial x^{\alpha}} + \sqrt{g_{00}^{(+)}} \left(\frac{\partial g_{\beta}^{(+)}}{\partial x^{\alpha}} - \frac{\partial g_{\alpha}^{(+)}}{\partial x^{\beta}} \right) \frac{v^{(+)\beta}}{c} \right\}, \quad (105)$$

$$a_{\alpha}^{(-)} = \frac{c^2}{\sqrt{1-\frac{v^{(-)^2}}{c^2}}} \left\{ -\frac{\partial \ln \sqrt{g_{00}^{(-)}}}{\partial x^{\alpha}} + \sqrt{g_{00}^{(-)}} \left(\frac{\partial g_{\beta}^{(-)}}{\partial x^{\alpha}} - \frac{\partial g_{\alpha}^{(-)}}{\partial x^{\beta}} \right) \frac{v^{(-)\beta}}{c} \right\}. \quad (106)$$

In this case, the acceleration vector of the local region of the 2^3 - $\lambda_{m,n}$ -vacuum, taking into account (100) – (101) has the form

$$\mathbf{a}^{(\pm)} = \frac{1}{\sqrt{2}} (\mathbf{a}^{(+)} + i \mathbf{a}^{(-)}), \quad (107)$$

where $\mathbf{a}^{(\pm)} = \vec{a}^{(\pm)} \left(\frac{1}{\sqrt{2}} (a_1^{(+)} + i a_1^{(-)}), \frac{1}{\sqrt{2}} (a_2^{(+)} + i a_2^{(-)}), \frac{1}{\sqrt{2}} (a_3^{(+)} + i a_3^{(-)}) \right)$.

5 Geometrized Lorentz force

5.1 Geometricized vectors of eclectic tension and magnetic induction

Consider the vector Ex. (95)

$$\mathbf{a} = \vec{a} = \frac{1}{\sqrt{1-\frac{v^2}{c^2}}} c^2 \left\{ -\text{grad}(\ln \sqrt{g_{00}}) + \sqrt{g_{00}} \left[\frac{\vec{v}}{c} \times \text{rot} \vec{g} \right] \right\}, \quad (108)$$

where $\vec{g} \left(-\frac{g_{01}}{g_{00}}, -\frac{g_{01}}{g_{00}}, -\frac{g_{01}}{g_{00}} \right)$ is a 3-dimensional vector.

We introduce the notation

$$\mathbf{E}_v = \vec{E}_v = -\gamma_c \text{grad} \varphi, \quad (109)$$

$$\mathbf{B}_v = \vec{B}_v = \gamma_c \sqrt{g_{00}} \text{rot} \frac{\vec{A}}{c}, \quad (110)$$

where

$$\varphi = \ln \sqrt{g_{00}} - \text{geometrized scalar potential}; \quad (111)$$

$$\vec{A} = \vec{g} - \text{geometrized vector potential}; \quad (112)$$

$$\gamma_c = \frac{c^2}{\sqrt{1 - \frac{v^2}{c^2}}}, \quad \text{– Lorentz-factor multiplied by } c^2. \quad (113)$$

Taking into account notations (109) – (113), the acceleration vector (108) takes the form

$$\mathbf{a} = \mathbf{E}_v + [\mathbf{v} \times \mathbf{B}_v], \quad (114)$$

Let's compare this acceleration vector with the Lorentz force

$$\mathbf{F}_l = q\mathbf{E} + q[\mathbf{v} \times \mathbf{B}] \quad \text{or} \quad \mathbf{F}_l/q = \mathbf{E} + [\mathbf{v} \times \mathbf{B}], \quad (115)$$

where

\mathbf{E} is electric field strength vector;

\mathbf{B} is magnetic field induction vector;

q is the charge of the particle.

The obvious analogy of expressions (114) and (115) allows us to consider vectors (109) and (110) as:

\mathbf{E}_v is the geometrized vector of electric field strength with components:

$$E_{v1} = \gamma_c \frac{\partial \ln \sqrt{g_{00}}}{\partial x^1}, \quad E_{v2} = \gamma_c \frac{\partial \ln \sqrt{g_{00}}}{\partial x^2}, \quad E_{v3} = \gamma_c \frac{\partial \ln \sqrt{g_{00}}}{\partial x^3}. \quad (116)$$

\mathbf{B}_v is the geometrized vector of magnetic induction with components:

$$B_{v1} = \gamma_c \sqrt{g_{00}} \left(\frac{\partial g_3}{\partial x^2} - \frac{\partial g_2}{\partial x^3} \right), \quad B_{v2} = \gamma_c \sqrt{g_{00}} \left(\frac{\partial g_1}{\partial x^3} - \frac{\partial g_3}{\partial x^1} \right), \quad B_{v3} = \gamma_c \sqrt{g_{00}} \left(\frac{\partial g_2}{\partial x^1} - \frac{\partial g_1}{\partial x^2} \right). \quad (117)$$

where

$$g_1 = -\frac{g_{01}}{g_{00}}, \quad g_2 = -\frac{g_{02}}{g_{00}}, \quad g_3 = -\frac{g_{03}}{g_{00}}. \quad (118)$$

5.2 The meaning of geometrized vectors of electric field strength \mathbf{E}_v and magnetic induction \mathbf{B}_v

To clarify the meaning of the vectors \mathbf{E}_v and \mathbf{B}_v , consider the arbitrary motion of an affine space with signature $\{++++\}$ (i.e., reference frame) $K'(t',x',y',z')$ relative to a stationary affine space with signature $\{++++\}$ (i.e. frame of reference) $K(t,x,y,z)$ (see Figure 8). This well-known classical task is borrowed from [7] in full, because otherwise, establishing the meaning of the vectors \mathbf{E}_v and \mathbf{B}_v will be very problematic.

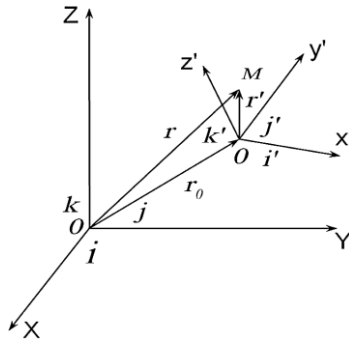

Rice. 8: Motion of the reference frame (or affine space) K' with signature $\{++++\}$ relative the rest reference frame (or affine space) K with signature $\{++++\}$

The Figure 8 shows that the radius vectors \mathbf{r} and \mathbf{r}' , which define the position of point M in the systems K and K' are related by the relation

$$\mathbf{r} = \mathbf{r}_0 + \mathbf{r}' \quad (119)$$

$$\text{or } \mathbf{i}x + \mathbf{j}y + \mathbf{k}z = \mathbf{r}_0 + \mathbf{i}'x' + \mathbf{j}'y' + \mathbf{k}'z', \quad (120)$$

where

$\mathbf{i}, \mathbf{j}, \mathbf{k}$ are orthogonal unit vectors that specify the directions of the axes of a fixed affine space K with signature $\{+++ \}$; $\mathbf{i}', \mathbf{j}', \mathbf{k}'$ are orthogonal unit vectors that specify the directions of the axes of a moving affine space K' with signature $\{+++ \}$.

The speed of point M (belonging to the reference frame, or affine space, K') relative to the reference frame K at $t' = t$ is obtained as a result of differentiating both sides of Ex. (119) [7]

$$\mathbf{v}_a = d\mathbf{r}/dt = d\mathbf{r}_0/dt + d\mathbf{r}'/dt, \quad (121)$$

in this case, taking into account Ex. (120) we have

$$\mathbf{v}_a = \mathbf{v}_0 + (x'd\mathbf{i}'/dt + y'd\mathbf{j}'/dt + z'd\mathbf{k}'/dt) + (\mathbf{i}'dx'/dt + \mathbf{j}'dy'/dt + \mathbf{k}'dz'/dt). \quad (122)$$

Let the vectors $\mathbf{i}', \mathbf{j}', \mathbf{k}'$ of the moving reference frame K' can change relative to the reference frame K only due to its rotation around the point O' with angular velocity $\boldsymbol{\Omega}$. Therefore, the time derivatives of the unit vectors $\mathbf{i}', \mathbf{j}', \mathbf{k}'$ equal to the speeds of the ends of these vectors during rotation of the reference frame K' [7]

$$d\mathbf{i}'/dt = [\boldsymbol{\Omega} \times \mathbf{i}'], \quad d\mathbf{j}'/dt = [\boldsymbol{\Omega} \times \mathbf{j}'], \quad d\mathbf{k}'/dt = [\boldsymbol{\Omega} \times \mathbf{k}']. \quad (123)$$

Substituting Exs. (123) into Ex. (122), we obtain

$$\mathbf{v}_a = \mathbf{v}_0 + [\boldsymbol{\Omega} \times \mathbf{r}'] + (\mathbf{i}'dx'/dt + \mathbf{j}'dy'/dt + \mathbf{k}'dz'/dt). \quad (124)$$

The acceleration of point M relative to the reference frame K at $t' = t$ is equal to [7]

$$\mathbf{a} = d\mathbf{v}_a/dt = \mathbf{a}_r + \mathbf{a}_e + \mathbf{a}_k, \quad (125)$$

where

$$\mathbf{a}_r = (\mathbf{i}'d^2x'/dt^2 + \mathbf{j}'d^2y'/dt^2 + \mathbf{k}'d^2z'/dt^2) \text{ is relative acceleration;} \quad (126)$$

$$\mathbf{a}_e = d\mathbf{v}_0/dt + [d\boldsymbol{\Omega}/dt \times \mathbf{r}'] + [\boldsymbol{\Omega} \times [\boldsymbol{\Omega} \times \mathbf{r}']] \text{ is portable acceleration;} \quad (127)$$

$$\mathbf{a}_k = 2[\boldsymbol{\Omega} \times \mathbf{v}_r] \text{ is Coriolis acceleration.} \quad (128)$$

We rewrite Ex. (125) for the stationary case $d\mathbf{v}_0/dt = 0$ and $[d\boldsymbol{\Omega}/dt \times \mathbf{r}'] = 0$,

$$\mathbf{a} = \mathbf{a}_{pc} + 2[\boldsymbol{\Omega} \times \mathbf{v}_r], \quad (129)$$

where

$$\mathbf{a}_{pc} = (\mathbf{i}'d^2x'/dt^2 + \mathbf{j}'d^2y'/dt^2 + \mathbf{k}'d^2z'/dt^2) + [\boldsymbol{\Omega} \times [\boldsymbol{\Omega} \times \mathbf{r}']] \quad (130)$$

is stationary relative-transportable acceleration of the moving reference frame K'

Taking into account the relation known in analytical geometry

$$[\mathbf{\Omega} \times \mathbf{v}_r] = -[\mathbf{v}_r \times \mathbf{\Omega}], \quad (131)$$

Ex. (129) can be represented as

$$\mathbf{a} = \mathbf{a}_{pc} - 2[\mathbf{v}_r \times \mathbf{\Omega}]. \quad (132)$$

When comparing acceleration (132) with acceleration (114)

$$\mathbf{a} = \mathbf{E}_v + [\mathbf{v} \times \mathbf{B}_v],$$

we find the following obvious analogy

$$\mathbf{E}_v \equiv \mathbf{a}_{pc}, \quad \mathbf{B}_v \equiv -2\mathbf{\Omega}, \quad \mathbf{v} \equiv \mathbf{v}_r. \quad (133)$$

Thus, it turns out the following:

- the geometrized vector of electric field strength \mathbf{E}_v of the vacuum layer is identical to the stationary transport acceleration with torsion \mathbf{a}_{pc} (130) of the local area of the moving affine space K' in the vicinity of the point M relative to the resting affine space K ;
- the geometrized vector of magnetic induction \mathbf{B}_v of the vacuum layer is identical to the doubled stationary angular velocity of rotation $\mathbf{\Omega}$ of the same area of moving affine space K' in the vicinity of the point M relative to the resting affine space K ;
- the velocity vector \mathbf{v} of the vacuum layer corresponds to the constant displacement velocity \mathbf{v}_r of the same area of the affine space K' relative to the affine space K .

Within the Algebra of Signatures, each of the reference frames $K'(t', x', y', z')$ and $K(t, x, y, z)$ can have any of the 16 possible bases unit vector shown in Figure 7 in [1], with the corresponding signature from matrix (68)

$$\text{stign}(e_i^{(a)}) = \begin{pmatrix} \{++++\} & \{+++-\} & \{-++-\} & \{+-+ -\} \\ \{- - - +\} & \{-+++ \} & \{- - + +\} & \{-+ - +\} \\ \{+ - - +\} & \{+ + - -\} & \{+ - - -\} & \{+ - + +\} \\ \{- - + -\} & \{+ - + -\} & \{- + - -\} & \{- - - -\} \end{pmatrix}.$$

Therefore, within the framework of the Algebra of Signature, 256 options for the movement of two affine spaces relative to each other are possible.

Let's also note that the complete analogy between vectors (132) and (114) is due to the fact that they were obtained under the same stationarity $d\mathbf{v}_0/dt = 0$ and $[d\mathbf{\Omega}/dt \times \mathbf{r}'] = 0$, and at the same simplifications corresponding to Riemannian geometry (see Figure 4a), i.e. only the displacement and rotation of the reference frame K' are taken into account while maintaining the sizes of the basis vectors $\mathbf{i}', \mathbf{j}', \mathbf{k}'$ (or $\mathbf{e}_1^{(a)}, \mathbf{e}_2^{(a)}, \mathbf{e}_3^{(a)}$) and the angles between them.

A similar analysis can be performed for more complex cases, when all four parameters $\alpha_{ij}^{(a)}, \beta^{pm(a)}, \mathbf{e}_m^{(a)}, dx^{j(a)}$ both of the reference frame K' and the reference frame K can change (see Figure 4b), and this will correspond to the more complex differential geometry, for example, such as the geometry of absolute parallelism.

6 Geometrized vectors of electric field strength and magnetic induction of the 2^k - $\lambda_{m,n}$ -vacuum

6.1 Geometrized vectors of electric field strength and magnetic induction of the 2^3 - $\lambda_{m,n}$ -vacuum

Let's return to the consideration of a stationary curved area of a two-sided 2^3 - $\lambda_{m,n}$ -vacuum within the framework of the Algebra of Signature representations with simplifications related to Riemannian geometry (see Figure 4a).

In § 4.4, the acceleration vector of the stationary area of the $2^3\text{-}\lambda_{m,n}$ -vacuum (107) was obtained

$$\mathbf{a}^{(\pm)} = \frac{1}{\sqrt{2}} (\mathbf{a}^{(+)} + i\mathbf{a}^{(-)}), \quad (134)$$

where, according to Exs. (100) – (101) and § 5.1,

$$\mathbf{a}^{(+)} = \vec{a}^{(+)} = \frac{c^2}{\sqrt{1-\frac{v^{(+)^2}}{c^2}}} \left\{ -grad \left(\ln \sqrt{g_{00}^{(+)}} \right) + \sqrt{g_{00}^{(+)}} \left[\frac{\vec{v}^{(+)}}{c} \times rot \vec{g}^{(+)} \right] \right\} = \mathbf{E}_v^{(+)} + [\mathbf{v}^{(+)} \times \mathbf{B}_v^{(+)}], \quad (135)$$

$$\mathbf{a}^{(-)} = \vec{a}^{(-)} = \frac{c^2}{\sqrt{1-\frac{v^{(-)^2}}{c^2}}} \left\{ -grad \left(\ln \sqrt{g_{00}^{(-)}} \right) + \sqrt{g_{00}^{(-)}} \left[\frac{\vec{v}^{(-)}}{c} \times rot \vec{g}^{(-)} \right] \right\} = \mathbf{E}_v^{(-)} + [\mathbf{v}^{(-)} \times \mathbf{B}_v^{(-)}]. \quad (136)$$

Let's substitute the acceleration vectors (135) and (136) into Ex. (134), as a result we obtain

$$\mathbf{a}^{(\pm)} = \frac{1}{\sqrt{2}} \{ \mathbf{E}_v^{(+)} + [\mathbf{v}^{(+)} \times \mathbf{B}_v^{(+)}] + i (\mathbf{E}_v^{(-)} + [\mathbf{v}^{(-)} \times \mathbf{B}_v^{(-)}]) \}, \quad (137)$$

or

$$\mathbf{a}^{(\pm)} = \frac{1}{\sqrt{2}} \{ (\mathbf{E}_v^{(+)} + i\mathbf{E}_v^{(-)}) + ([\mathbf{v}^{(+)} \times \mathbf{B}_v^{(+)}] + i [\mathbf{v}^{(-)} \times \mathbf{B}_v^{(-)}]) \}. \quad (138)$$

where according to expressions (116) – (118):

$\mathbf{E}_v^{(+)}$ is geometrized vector of the electric field strength of *subcont*, with components:

$$E_{v1}^{(+)} = \gamma_c \frac{\partial \ln \sqrt{g_{00}^{(+)}}}{\partial x^1}, \quad E_{v2}^{(+)} = \gamma_c \frac{\partial \ln \sqrt{g_{00}^{(+)}}}{\partial x^2}, \quad E_{v3}^{(+)} = \gamma_c \frac{\partial \ln \sqrt{g_{00}^{(+)}}}{\partial x^3}. \quad (139)$$

$\mathbf{B}_v^{(+)}$ is geometrized vector of the magnetic induction with of *subcont*, with components:

$$B_{v1}^{(+)} = \gamma_c \sqrt{g_{00}^{(+)}} \left(\frac{\partial g_3^{(+)}}{\partial x^2} - \frac{\partial g_2^{(+)}}{\partial x^3} \right), \quad B_{v2}^{(+)} = \gamma_c \sqrt{g_{00}^{(+)}} \left(\frac{\partial g_1^{(+)}}{\partial x^3} - \frac{\partial g_3^{(+)}}{\partial x^1} \right), \quad B_{v3}^{(+)} = \gamma_c \sqrt{g_{00}^{(+)}} \left(\frac{\partial g_2^{(+)}}{\partial x^1} - \frac{\partial g_1^{(+)}}{\partial x^2} \right). \quad (140)$$

$$\text{here } g_1^{(+)} = -\frac{g_{01}^{(+)}}{g_{00}^{(+)}} \text{, } g_2^{(+)} = -\frac{g_{02}^{(+)}}{g_{00}^{(+)}} \text{, } g_3^{(+)} = -\frac{g_{03}^{(+)}}{g_{00}^{(+)}}. \quad (141)$$

$\mathbf{E}_v^{(-)}$ is geometrized vector of the electric field strength of *antisubcont*, with components:

$$E_{v1}^{(-)} = \gamma_c \frac{\partial \ln \sqrt{g_{00}^{(-)}}}{\partial x^1}, \quad E_{v2}^{(-)} = \gamma_c \frac{\partial \ln \sqrt{g_{00}^{(-)}}}{\partial x^2}, \quad E_{v3}^{(-)} = \gamma_c \frac{\partial \ln \sqrt{g_{00}^{(-)}}}{\partial x^3}. \quad (142)$$

$\mathbf{B}_v^{(-)}$ is geometrized vector of the magnetic induction with of *antisubcont*, with components:

$$B_{v1}^{(-)} = \gamma_c \sqrt{g_{00}^{(-)}} \left(\frac{\partial g_3^{(-)}}{\partial x^2} - \frac{\partial g_2^{(-)}}{\partial x^3} \right), \quad B_{v2}^{(-)} = \gamma_c \sqrt{g_{00}^{(-)}} \left(\frac{\partial g_1^{(-)}}{\partial x^3} - \frac{\partial g_3^{(-)}}{\partial x^1} \right), \quad B_{v3}^{(-)} = \gamma_c \sqrt{g_{00}^{(-)}} \left(\frac{\partial g_2^{(-)}}{\partial x^1} - \frac{\partial g_1^{(-)}}{\partial x^2} \right). \quad (143)$$

$$\text{here } g_1^{(-)} = -\frac{g_{01}^{(-)}}{g_{00}^{(-)}} \text{, } g_2^{(-)} = -\frac{g_{02}^{(-)}}{g_{00}^{(-)}} \text{, } g_3^{(-)} = -\frac{g_{03}^{(-)}}{g_{00}^{(-)}}. \quad (144)$$

We recall that time-independent components of the metric tensors $g_{ij}^{(+)} = const$ and $g_{ij}^{(-)} = const$ from the conjugate stationary metrics (72):

$$\begin{cases} ds^{(+2)} = g_{00}^{(+)}(dx^0)^2 + 2g_{0\alpha}^{(+)} dx^0 dx^\alpha + g_{\alpha\beta}^{(+)} dx^\alpha dx^\beta \text{ is metric of stationary } subcont \text{ (see Figure 2),} \\ ds^{(-2)} = g_{00}^{(-)}(dx^0)^2 + 2g_{0\alpha}^{(-)} dx^0 dx^\alpha + g_{\alpha\beta}^{(-)} dx^\alpha dx^\beta \text{ is metric of stationary } antisubcont \end{cases} \quad (145)$$

are substituted into Exs. (139) – (144).

Taking into account Exs. (139) – (144), the components of the 3-dimensional acceleration vector of the stationary curved local area of the two-sided 2^3 - $\lambda_{m,n}$ -vacuum $\mathbf{a}^{(\pm)}$ (138) are equal to the modules of complex numbers: $\mathbf{a}^{(\pm)} \left(|a_1^{(\pm)}|, |a_2^{(\pm)}|, |a_3^{(\pm)}| \right)$, where:

$$a_1^{(\pm)} = \frac{1}{\sqrt{2}} \left\{ (E_{v1}^{(+)} + i E_{v1}^{(-)}) + [(v_2^{(+)} B_{v3}^{(+)} - v_3^{(+)} B_{v2}^{(+)}) + i(v_2^{(-)} B_{v3}^{(-)} - v_3^{(-)} B_{v2}^{(-)})] \right\}, \quad (146)$$

$$a_2^{(\pm)} = \frac{1}{\sqrt{2}} \left\{ (E_{v2}^{(+)} + i E_{v2}^{(-)}) + [(v_3^{(+)} B_{v1}^{(+)} - v_1^{(+)} B_{v3}^{(+)}) + i(v_3^{(-)} B_{v1}^{(-)} - v_1^{(-)} B_{v3}^{(-)})] \right\},$$

$$a_3^{(\pm)} = \frac{1}{\sqrt{2}} \left\{ (E_{v3}^{(+)} + i E_{v3}^{(-)}) + [(v_1^{(+)} B_{v2}^{(+)} - v_2^{(+)} B_{v1}^{(+)}) + i(v_1^{(-)} B_{v2}^{(-)} - v_2^{(-)} B_{v1}^{(-)})] \right\}.$$

or according to Ex. (137)

$$a_1^{(\pm)} = \frac{1}{\sqrt{2}} \left\{ [E_{v1}^{(+)} + (v_2^{(+)} B_{v3}^{(+)} - v_3^{(+)} B_{v2}^{(+)})] + i[E_{v1}^{(-)} + (v_2^{(-)} B_{v3}^{(-)} - v_3^{(-)} B_{v2}^{(-)})] \right\}, \quad (147)$$

$$a_2^{(\pm)} = \frac{1}{\sqrt{2}} \left\{ [E_{v2}^{(+)} + (v_3^{(+)} B_{v1}^{(+)} - v_1^{(+)} B_{v3}^{(+)})] + i[E_{v2}^{(-)} + (v_3^{(-)} B_{v1}^{(-)} - v_1^{(-)} B_{v3}^{(-)})] \right\},$$

$$a_3^{(\pm)} = \frac{1}{\sqrt{2}} \left\{ [E_{v3}^{(+)} + (v_1^{(+)} B_{v2}^{(+)} - v_2^{(+)} B_{v1}^{(+)})] + i[E_{v3}^{(-)} + (v_1^{(-)} B_{v2}^{(-)} - v_2^{(-)} B_{v1}^{(-)})] \right\}.$$

We recall that these results were obtained for the simplest level of consideration, i.e. for a two-sided 2^3 - $\lambda_{m,n}$ -vacuum with simplifications corresponding to Riemannian geometry, and in the case of constancy of the *subcont* metric tensors $g_{ij}^{(+)} = const$ and *antisubcont* $g_{ij}^{(-)} = const$.

6.2 Geometricized vectors of electric field strength and magnetic induction of the 2^6 - $\lambda_{m,n}$ -vacuum

At the level of considering a 16-sided 2^6 - $\lambda_{m,n}$ -vacuum with similar simplifications and stationarity conditions, based on Ex. (47), we similarly obtain

$$\begin{aligned} \mathbf{a}_{\Sigma 16} = 1/\sqrt{16} (\eta_1 \mathbf{a}^{(1)} + \eta_2 \mathbf{a}^{(2)} + \eta_3 \mathbf{a}^{(3)} + \eta_4 \mathbf{a}^{(4)} + \\ + \eta_5 \mathbf{a}^{(5)} + \eta_6 \mathbf{a}^{(6)} + \eta_7 \mathbf{a}^{(7)} + \eta_8 \mathbf{a}^{(8)} + \\ + \eta_9 \mathbf{a}^{(9)} + \eta_{10} \mathbf{a}^{(10)} + \eta_{11} \mathbf{a}^{(11)} + \eta_{12} \mathbf{a}^{(12)} + \\ + \eta_{13} \mathbf{a}^{(13)} + \eta_{14} \mathbf{a}^{(14)} + \eta_{15} \mathbf{a}^{(15)} + \eta_{16} \mathbf{a}^{(16)}), \end{aligned} \quad (148)$$

where

$$\mathbf{a}^{(q)} = \vec{a}^{(q)} = \frac{c^2}{\sqrt{1 - \frac{v^{(q)2}}{c^2}}} \left\{ -grad \left(\ln \sqrt{g_{00}^{(q)}} \right) + \sqrt{g_{00}^{(q)}} \left[\frac{\vec{v}^{(q)}}{c} \times rot \vec{g}^{(q)} \right] \right\} = \mathbf{E}_v^{(q)} + [\mathbf{v}^{(q)} \times \mathbf{B}_v^{(q)}], \quad (149)$$

$$\text{where } g_\alpha^{(q)} = -\frac{g_{0\alpha}^{(q)}}{g_{00}^{(q)}},$$

in this case, the time-independent components of the metric tensors $g_{ij}^{(q)} = const$ are taken from sixteen interconnected stationary metrics

$$ds^{(q)2} = g_{00}^{(q)}(dx^0)^2 + 2g_{0\alpha}^{(q)} dx^0 dx^\alpha + g_{\alpha\beta}^{(q)} dx^\alpha dx^\beta \text{ with the corresponding signature from matrix (35).} \quad (150)$$

The dynamics of the next deeper level of stationary $2^{10-\lambda_{m,n}}$ -vacuum and the dynamics of all subsequent deeper $2^k-\lambda_{m,n}$ -vacuums (with k tending to infinity) can be developed similarly.

CONCLUSIONS

In this fourth part of the scientific project under the general title “Geometrized vacuum physics”, the dynamics of vacuum layers is considered using the Algebra of Signature (Alsigna), the foundations of which are presented in [1,2,3].

This article continues the development of Alsigna’s mathematical apparatus for studying accelerated processes in $\lambda_{m,n}$ -vacuum layers at the simplest levels of consideration: $2^3-\lambda_{m,n}$ -vacuum and $2^6-\lambda_{m,n}$ -vacuum. In this case, the main results were obtained with simplifications related to Riemannian geometry.

At the same time, methods are given to expand the capabilities of differential geometry by increasing the complexity of the considered types of distortions of metric spaces with different signatures (i.e., topologies), which are considered as adjacent layers of $2^k-\lambda_{m,n}$ -vacuum.

At the end of the article, the acceleration of layers of a $2^k-\lambda_{m,n}$ -vacuum, which is in a stationary state (i.e., unchanged with time), is considered. In this case, with simplifications related to Riemannian geometry, it was possible to show that stable intertwined, accelerated laminar and rotational flows of a $2^k-\lambda_{m,n}$ -vacuum can be described in terms of vacuum electric field strength and vacuum magnetic induction.

This result may be important, since it allows us to outline ways of conscious control of intra-vacuum processes by generating electromagnetic fields of a given configuration.

Thus, the stationary dynamic models of accelerated and rotational movements of a $2^k-\lambda_{m,n}$ -vacuum layers proposed in this article can serve as a theoretical basis for the development of “vacuum electromagnetic dynamics” and subsequently for increasing the capabilities of “zero” (i.e. vacuum) technologies.

In subsequent articles of the “Geometrized vacuum physics” it will be shown that Riemannian geometry, taking into account the Algebra of Signature, may be sufficient to create geometrized mathematical models of the standard Universe, all elementary particles, electromagnetic phenomena, nuclear and gravitational interactions and many others physical processes. In other words, a project aimed at the complete geometrization of inanimate physics does not require a radical complication of the original differential geometry.

However, it later became clear that it is impossible to create a completely complete mathematical model of the Universe without developing the most complex version of differential geometry, which takes into account all types of distortions (see Figure 4b) of intertwined spaces with different signatures (i.e. topologies). Some directions of development of differential geometry are indicated in §3. Many steps in this direction have already been made in the geometries of Weyl, Eddington, Lobachevsky, Klein, Cartan - Schouten, Penrose, Finsler, Weizenbeck - Vitali - Shipov, etc. However, an all-encompassing differential geometry has not yet been created, and this does not allow physicists to break out of the circle outlined by simplified versions of geometries.

REFERENCES

1. Batanov-Gaukhman, M. Geometrized Vacuum Physics. Part I. Algebra of Stignatures. *Preprints* 2023, 2023060765. <https://doi.org/10.20944/preprints202306.0765.v3>.
2. Batanov-Gaukhman, M. Geometrized Vacuum Physics. Part II. Algebra of Signatures. *Preprints* 2023, 2023070716. <https://doi.org/10.20944/preprints202307.0716.v1>.
3. Batanov-Gaukhman, M. Geometrized Vacuum Physics. Part III. Curved Vacuum Area. *Preprints* 2023, 2023080570. <https://doi.org/10.20944/preprints202308.0570.v4>.

4. Shipov G. (1997). Geometry of absolute parallelism, – Moscow: Science, 134 p.
5. Landau L.D., Lifshitz E.M. (1971) The Classical Theory of Fields / Course of theoretical physics, V. 2 Translated from the Russian by Hamermesh M. University of Minnesota – Pergamon Press Ltd. Oxford, New York, Toronto, Sydney, Braunschweig, p. 387.
6. Shipov, G. (1998). "A Theory of Physical Vacuum". Moscow ST-Center, Russia ISBN 5 7273-0011-8.
7. Detlaf A.A., Yavorsky B.M. (1989) "Physics Course". – Moscow: Higher School, ISBN: 5-06-003556-5